

MODEL NRS-12/20 BATTERY CHARGER

PLEASE SAVE THESE IMPORTANT SAFETY AND OPERATING INSTRUCTIONS

For correct operation of the equipment, it is important to read and be familiar with this entire manual before installing and operating the charger.
DO NOT DISCARD THIS MANUAL AFTER READING.



LOOK FOR THIS SYMBOL TO POINT OUT SAFETY PRECAUTIONS. IT MEANS: *BECOME ALERT—YOUR SAFETY IS INVOLVED.* IF YOU DO NOT FOLLOW THESE SAFETY INSTRUCTIONS, INJURY OR PROPERTY DAMAGE CAN OCCUR.

1. IMPORTANT SAFETY INSTRUCTIONS

- a. Before using the battery charger, read all the instructions and caution markings on the battery charger, the battery, and all of the products using the battery.
- b. Do not touch the uninsulated parts of the AC input or the DC wires, the charger's binding posts, or the battery terminals as there is a possibility of electrical shock.
- c. Batteries produce hydrogen gas while operating, which can explode if ignited. Never smoke, use an open flame, or create sparks in the vicinity of the battery. Ventilate the area well when the battery is charging in an enclosed area.
- d. Batteries contain caustic material which may cause burns. Do not get in eyes, on skin, or clothing. If the gelled or liquid content of the batteries contacts the skin or clothing, wash the area thoroughly with water. In the case of contact with the eyes, flush immediately with clean water for 15 minutes and obtain medical attention.
- e. Only qualified personnel should program or service this equipment.
- f. De-energize all AC and DC power connections before servicing this unit. If injury does occur, apply standard treatment for electrical shock and, if necessary, consult with a physician.
- g. The charger is not for outdoor use. Do not expose the charger to rain or snow.
- h. Do not operate the charger if it has received a sharp blow, been dropped, or otherwise damaged.
- i. Do not disassemble the charger. Have the charger examined by a NATIONAL RAILWAY SUPPLY, INC. service agent. If the charger is assembled incorrectly, damage to the charger and the batteries or an electrical shock may result.

2. DESCRIPTION

The NATIONAL RAILWAY SUPPLY, INC. charger, model 12/20, is a convection-cooled, solid state, SCR regulated charger that provides either a constant current or constant voltage output. The charger can be set to charge batteries within a voltage range of 10.00 to 19.99 volts for gel-cell, liquid lead-acid, nickel cadmium, nickel iron, and starved electrolytic batteries.

3. THEORY OF OPERATION

When the charger is connected to the desired AC voltage source (115 or 230), the transformer creates auxiliary voltages for the electronic control module. The electronic control module controls and monitors the charger so it will perform properly. The transformer also supplies the power output used for charging the batteries and provides electrical isolation between the charger's output and the AC source.

The charger's output current flows through a shunt and is sensed by the electronic control module along with the charger's output voltage. These values are converted into drive pulses for the SCRs by the control module. This pulsating charge current (a pulse occurs each time an SCR is on) is then filtered by a large capacitor and the batteries to provide a smooth output.

The charger is an "IE" profile which is: (a) High rate constant current, and (b) Constant voltage. When the charger is first started, the SCRs will conduct for a certain portion of the sinusoidal anode voltage to provide the required charging current at the low level of battery voltage. In this start region, a constant current is applied to the battery. The SCR conduction will then increase as the battery voltage increases in order to provide a higher output voltage while maintaining a constant charging current.

When the battery voltage reaches the float voltage, the SCRs will start to decrease their output. This causes the charger to automatically change from a constant current charge region to a constant voltage charge region. As the batteries become fully charged, the output current decreases. A continuous constant float voltage will be supplied to the batteries to maintain their charge.

Another feature of the charger is temperature compensation, which keeps the batteries from getting under- or over-charged. **TEMPERATURE COMPENSATION ONLY OCCURS WHEN USING A TEMPERATURE PROBE.** The red LED on the front of the charger will be off when using a functional temperature probe. If the LED is on, either a temperature probe is not being used, or the temperature probe is working improperly.

Temperature compensation uses a temperature reference of 77°F (25°C), a voltage reference of 2.23 volts (the voltage of a standard gel-cell battery at 77°F), and a compensation value of 3.0 mV per °F, or 5.4 mV per °C. The equivalent equation for the compensated voltage is:

$$V_{\text{comp}} = V - k (t - 77^{\circ}\text{F})$$

Where V is the voltage of the battery at 77°F, t is the temperature in °F, and $k = V (.003 / 2.23)$.

The control module has a temperature compensation range between 32°F and 95°F (0°C and 35°C) that does not allow charger voltage to increase or decrease beyond the calculated values.

Example 1:

If a 13.38 volt battery is charging and the temperature increases to 95°F, then the output voltage decreases to 13.06 volts.

$$13.38 - .018 (95^{\circ}\text{F} - 77^{\circ}\text{F}) = 13.06$$

Example 2:

If a 14.50 volt battery is charging and the temperature increases to 95°F, then the output voltage decreases to 14.15 volts.

$$14.50 - .0195 (95^{\circ}\text{F} - 77^{\circ}\text{F}) = 14.15$$

Example 3:

If 15.61 volt batteries are charging and the temperature decreases to 32°F, the output voltage increases to 16.56 volts.

$$15.61 - .021 (32^{\circ}\text{F} - 77^{\circ}\text{F}) = 16.56$$

4. RECEIVING AND INSTALLING THE CHARGER

Proper installation of the charger is important in order to achieve good charger performance and to prevent damage to the charger and batteries. When a charger is received, a check for possible in-transit damage should be made. If any damage is found, it should be reported as a claim to the carrier. To permit free air flow for convection cooling, allow three inches (3") minimum between the charger sides and other equipment and four inches (4") minimum on top of the charger.

 **WARNING: NEVER PLACE ANYTHING ON TOP OF THE CHARGER WHILE OPERATING. DAMAGE TO THE CHARGER OR BATTERIES COULD OCCUR.**

 **WARNING: THE CHARGER MUST BE SET UP FOR THE PROPER USER SPECIFICATIONS BEFORE STARTING THE INITIAL CHARGE.**

5. AC ELECTRICAL SUPPLY

The charger must be connected to a single-phase, 50/100 Hertz AC power source, which can be either 115 or 230 VAC. Use an 8 AWG wire for the AC power input. Quarter-inch (1/4") ring terminals are required for proper connection to the AC input and ground binding posts (A.A.R.) located on the front of the charger. Remove the small door cover on the front of the charger by removing the two retaining screws. Connect the AC power terminals on the two posts on the left, as marked on the panel behind the posts.

Connect the AC ground to the terminal lug provided on the back plate between the mounting holes.

⚠ WARNING: FAILURE TO PROPERLY CONNECT THE AC VOLTAGE CONDUCTORS COULD CAUSE SERIOUS DAMAGE TO THE CHARGER. BE SURE TO SET THE VOLTAGE SELECTION SWITCHES ON THE FRONT OF THE CHARGER TO THEIR PROPER POSITION.

⚠ WARNING: DO NOT OPERATE THE CHARGER WITHOUT PROPER GROUNDING. IMPROPER GROUNDING CAN RESULT IN THE RISK OF AN ELECTRIC SHOCK.

6. DC OUTPUT

The DC output wires are connected on the two right-most binding posts as labeled on the top of the charger (positive on the left and negative on the right). The DC cables should have quarter-inch (1/4") ring terminals for connecting them to the binding posts. Check to make sure the polarity of the DC output wires is the same as those connected to the battery. The charger will not operate in a reversed polarity condition. **WHEN CONNECTING THE DC WIRES TO THE CHARGER WITH THE AC POWER DISCONNECTED, A SPARK MAY OCCUR.** This is caused by the output capacitors being charged by the batteries. If the DC polarity is reversed, a circuit breaker will protect the charger from internal damage. Correct the reversed wires and push the circuit breaker button back in. Replace the door cover on the front of the charger after tightening all of the binding post nuts.

⚠ WARNING: DO NOT TOUCH THE CHARGER'S TERMINALS OR AN ELECTRICAL SHOCK COULD OCCUR. A VOLTAGE IS PRESENT ON THE DC TERMINALS EVEN AFTER THE AC IS DISCONNECTED BECAUSE OF THE ENERGY STORED IN THE CAPACITOR.

7. TEMPERATURE PROBE

The external temperature probe is an optional way of extending battery life by using temperature compensation. One end of the temperature probe cable has a three-pin plug, which plugs into a receptacle labeled TEMP PROBE on the front of the charger. The other end of the cable has the temperature sensor sealed either in a terminal or small metal box.

⚠ WARNING: IT IS IMPORTANT TO MOUNT THE TEMPERATURE PROBE ON THE BATTERIES FOR PROPER TEMPERATURE COMPENSATION. IF

THIS CANNOT BE DONE, LOCATE THE PROBE AS LOW AS POSSIBLE IN THE BUNGALOW OR CABINET.

Terminal-Type Probe

The terminal-type probe should be attached to the negative (-) battery post near the center of the battery pack. If the threaded stud is long enough above the battery jumper nut, attach the probe with another nut. Torque this nut to proper specifications. If the stud is too short, the nut holding the jumper wire will need to be removed. Open or remove the load and charging circuits to the batteries. Remove the nut holding the jumper and add the probe, then torque the nut to the proper specifications. Then close or connect the load and charging circuits back to the batteries.

Box-Type Probe

The metal box has a high performance contact adhesive tape for attaching it to the battery. To attach, clean a spot for the probe on the middle battery about three inches (3") down from the top of the battery. Make sure the spot is free of all dirt and oil or the probe will not adhere properly. For proper adhesion, the battery surface must be cleaned with isopropyl alcohol. Ideal application temperature range is between 70 and 100°F. Initial application to surfaces at temperatures below 50°F is not recommended. Under cold conditions, the surface should be warmed before application. Once properly applied, low temperatures will not affect the bond strength.

Remove the adhesive's protective strip and press the probe firmly against the battery to ensure good adhesion.

Securely fasten the temperature probe cable to protect the probe from being torn from the battery. Secure the probe's cable to a fixed object to ensure the probe will not be pulled loose. Use a cable tie mount on the battery or on the adjacent battery, if necessary.

8. OPERATION

The battery charger is adjustable with the three rotary switches on the front of the charger. The switches (settable between 10.00 and 19.99) determine the float voltage for the batteries. **SET THE FLOAT VOLTAGE TO THE BATTERY MANUFACTURER'S SPECIFIED VOLTAGE FOR 77°F.** The charger will then electronically charge the batteries to the voltage specified on the switches. To set the switches, use a small screw-driver and turn the switch so that the arrow head on the slot is pointing to the desired number. Set the switches in the following manner: If the desired battery voltage is 13.38 volts, set the top switch to 3, the middle switch to 3, and the bottom

switch to 8 (see the figure below). This will provide you with the proper charging voltage. The tens digit is always a one (1) and cannot be changed. **BE SURE EACH SWITCH IS SET ON A NUMBER AND NOT BETWEEN NUMBERS.** If a switch is set between numbers, the output current will go to zero and the yellow charging LED will flash.

The charger does not have a power switch. When the AC power is applied to the charger, the DC output will start and the yellow LED will be on. To turn off the charger, disconnect the AC power source.

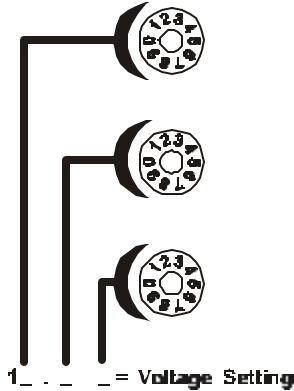

9. MAINTENANCE

The battery charger requires minimal maintenance. It should be kept clean and all connections are to be periodically tightened. **BE SURE THE CHASSIS IS SECURELY GROUNDED.** If any problem cannot be resolved, consult the nearest NRS service agent.

10. SERVICING

If the battery charger operates improperly, follow the steps below.

- a. Begin by checking the voltage switches to verify their settings against the specifications of the batteries.
- b. Check the AC voltage selection switch for the proper setting.
- c. Check the fuses to make sure they have not blown.
- d. Check the circuit breaker to see if it has opened and push it in to reset it, if necessary.

- e. Check the polarity between DC output and the battery and make sure their connections are tight.
- f. Remove the small cover on the front of the charger and make sure all of the binding posts nuts are tight.
- g. If the steps above do not solve the problem, contact your local NRS service agent.

11. CHARGER SPECIFICATIONS

AC INPUT VOLTAGE:

115 Vac (100-128) or 230 Vac (200-256)

AC INPUT CURRENT:

6.6 amps for 115 Vac (full power)

3.3 amps for 230 Vac (full power)

AC INPUT FREQUENCY:

48 – 100 Hertz (single phase)

AC LINE REGULATION:

For a constant output current at 2.23 volts/cell

+8% for 8 cells

+23.4% for 6 cells

AC FUSES:

MDA 4 or equivalent

POWER FACTOR:

Percentage at 20.0 amps DC current

56% at 13.8 volts

72% at 18.4 volts

DC OUTPUT:

Voltage range 10.00 – 19.00 ± 0.1 volts

Current Maximum 20.0 ± 5 amps

DC OUTPUT RIPPLE (at battery terminals):

0.25V p-p at 20.0 amps, 12.0 volts

0.1V p-p at 2.0 amps, 13.38 volts

TEMPERATURE COMPENSATION:

3±25mV per °F per cell

WEIGHT, NET:

30.2 lbs.

12. PARTS LIST

The following is a list of parts found in the NRS Model 12/20. When replacing a part, USE ONLY ORIGINAL FACTORY REPLACEMENT PARTS of the correct size and rating.

PART NO.	QTY.	DESCRIPTION
15091S	1	TRANSFORMER ASSEMBLY
18696S	1	SHUNT ASSEMBLY
29009S	1	CONTROL MODULE (W/ ELECTRONIC BOARD #21505)
14076S	1	CONTROL MODULE MOUNT
18806S	1	CONTROL CABLE
18834S	1	BASE ASSEMBLY
18829S	1	COVER ASSEMBLY
03837S	1	FUSEHOLDER ASSEMBLY
15834S	1	FUSE, 4 AMP
18799S	1	CIRCUIT BREAKER ASSEMBLY
18803S	1	AC SWITCH ASSEMBLY
15443S	1	AMMETER, 25 AMP
14197S	4	BUSHING, 1"
14123S	1	TEMPERATURE TRANSDUCER, 10' (BOX W/ ADHESIVE)
14124S	1	TEMPERATURE TRANSDUCER, 20' (BOX W/ ADHESIVE)
14126S	1	TEMPERATURE TRANSDUCER, 30' (BOX W/ ADHESIVE)
29741S	1	TEMPERATURE TRANSDUCER, 10' (W/ TERMINAL)
29742S	1	TEMPERATURE TRANSDUCER, 30' (W/ TERMINAL)
14108S	1	HEATSINK ASSEMBLY, W/ SCR
15909S	1	SCR ASSEMBLY, 16 AMP
14417S	1	OUTPUT CAPACITOR, C, 10,000 UF, 50V
14786S	1	DIODE ASSEMBLY, D
18796S	1	CAP ASSEMBLY, W/ DIODE ASSEMBLY
12717S	1	VARISTOR W/ CAP, VR1
15799S	1	TAP STRIP ASSEMBLY
14759S	1	VARISTOR ASSEMBLY, VR2
31126B	1	VARISTOR ASSEMBLY, AC, 320V, LOT SIZE 10

The adhesive used on the temperature probes (#s 14123S, 14124S, and 14126S) is 3M Scotch #Y-9473, which is a thermally conducting, two-sided adhesive tape. If a replacement adhesive is needed, use this type of tape or an equivalent adhesive.

13. WIRING DIAGRAM

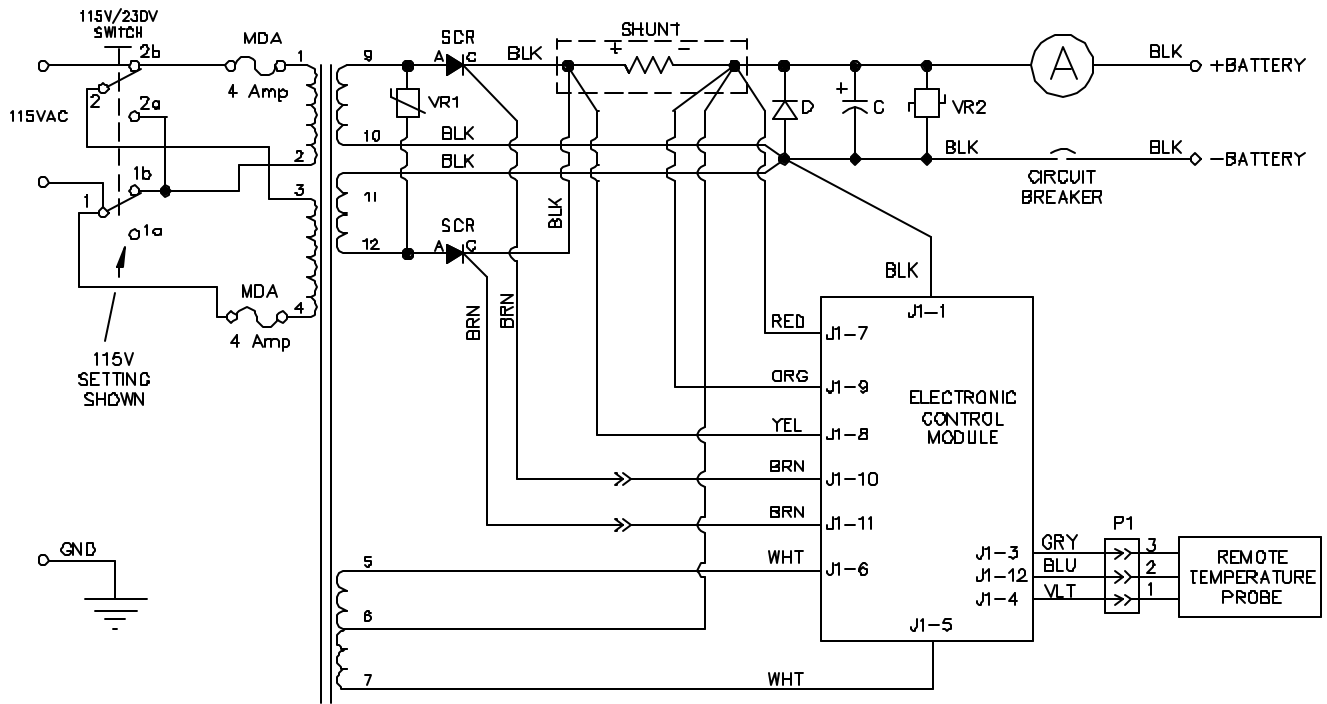

J1-1	BLack	-BATTERY
J1-2		NOT USED
J1-3	GRaY	TMP PROBE (-)
J1-4	ViOLeT	TMP PROBE (+)
J1-5	WHITe	AC XFRMR #7
J1-6	WHITe	AC XFRMR #5
J1-7	RED	+BATTERY
J1-8	YELlOW	SHUNT+
J1-9	ORanGe	SHUNT-
J1-10	BRoWn	SCR
J1-11	BRoWn	SCR
J1-12	BLUe	TEMP PROBE SENSE

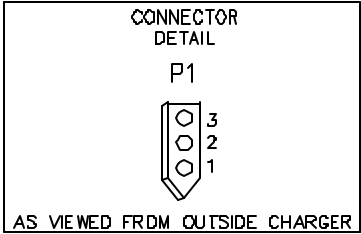

C	OUTPUT CAPACITOR
D	DIODE ASSEMBLY
VR1	VARIATOR WITH CAP.
VR2	VARIATOR