

**NATIONAL
RAILWAY
SUPPLY, INC.**



Installation, Operation and
Service Instructions for ERB-C
Shelf-Mount Solid State Chargers

ERB-C MODELS 12/201, 12/501 & 24/301 BATTERY CHARGERS

PLEASE SAVE THESE IMPORTANT SAFETY AND OPERATING INSTRUCTIONS

For correct operation of the equipment, it is important to read and be familiar with this entire manual before installing and operating the charger.
DO NOT DISCARD THIS MANUAL AFTER READING.



LOOK FOR THIS SYMBOL TO POINT OUT SAFETY PRECAUTIONS. IT MEANS: BECOME ALERT—YOUR SAFETY IS INVOLVED. IF YOU DO NOT FOLLOW THESE SAFETY INSTRUCTIONS, INJURY OR PROPERTY DAMAGE CAN OCCUR.

1. IMPORTANT SAFETY INSTRUCTIONS

- a. Before using the battery charger, read all the instructions and caution markings on the battery charger, the battery, and all of the products using the battery.
- b. Do not touch the uninsulated parts of the AC input or the DC wires, the charger's binding posts, or the battery terminals as there is a possibility of electrical shock.
- c. Batteries produce hydrogen gas while operating, which can explode if ignited. Never smoke, use an open flame, or create sparks in the vicinity of the battery. Ventilate the area well when the battery is charging in an enclosed area.
- d. Batteries contain caustic material which may cause burns. Do not get in eyes, on skin, or clothing. If the gelled or liquid content of the batteries contacts the skin or clothing, wash the area thoroughly with water. In the case of contact with the eyes, flush immediately with clean water for 15 minutes and obtain medical attention.
- e. Only qualified personnel should program or service this equipment.

- f. De-energize all AC and DC power connections before servicing this unit. If injury does occur, apply standard treatment for electrical shock and, if necessary, consult with a physician.
- g. The charger is not for outdoor use. Do not expose the charger to rain or snow.
- h. Do not operate the charger if it has received a sharp blow, been dropped, or otherwise damaged. Take it to a qualified service center.
- i. Do not disassemble the charger. Have the charger examined by a NATIONAL RAILWAY SUPPLY, INC. service agent or a local qualified service center. If the charger is assembled incorrectly, damage to the charger and the batteries or an electrical shock may result.

2. DESCRIPTION

The NATIONAL RAILWAY SUPPLY, INC. battery charger is a convection-cooled, solid state, SCR regulated charger that provides either a constant current or constant voltage output. It is designed to make battery charging simple and has a variety of

programmable options to personalize the charge profile.

The charger can be programmed to charge batteries within a cell range of: 1 to 8 cells (models 12/201 and 12/501), or 1 to 18 cells (model 24/301) for gel cell, liquid lead-acid, and valve-regulated batteries; and a cell range of 1 to 12 cells (models 12/201 and 12/501) or 1 to 24 cells (model 24/301) for nickel cadmium and nickel iron batteries. The charger has a comprehensive self-checking diagnostic program to monitor the quality of charge and check its own safety conditions. A three-digit display will show charge data, the programmed charger settings, and error codes. These values are useful to monitor and correct problems, if needed, with the charging system and with the battery.

3. THEORY OF OPERATION

When the charger is connected to the desired AC voltage source (115 or 230), the transformer creates auxiliary voltages for the electronic control module. The electronic control module has a microprocessor, which controls and monitors the charger so it will perform properly. The transformer also supplies the power output used for charging the batteries and provides electrical isolation between the charger's output and the AC source.

The charger's output current flows through a shunt and is sensed by the electronic control module along with the charger's output voltage. These values are converted into drive pulses for the SCRs by the control module. This pulsating charge current (a pulse occurs each time an SCR is on) is then filtered by a large capacitor and the batteries to provide a smooth output.

The charger is an "IE" profile which is (a) High rate constant current, and (b) Constant voltage. When the charger is first started, the SCRs will conduct for a certain portion of the sinusoidal anode voltage to provide the required charging current at the low level of battery voltage. In this start region, a constant current is applied to the battery. The SCR conduction will then increase as the battery voltage increases in order to provide a higher output voltage while maintaining a constant charging current.

When the battery voltage reaches the float voltage, the SCRs will start to decrease their output. This causes the charger to automatically change from a constant current charge region to a constant voltage charge region. As the batteries become fully charged, the output current decreases. A continuous constant float voltage will be supplied to the batteries to maintain their charge.

The electronic control module also senses the internal components of the charger for any change in their performance. When an external temperature probe is not used, the charger's internal temperature

sensor will be used for the temperature compensation (Functions 10 and 13). **ALL REFERENCES TO FUNCTION NUMBERS ARE FOUND UNDER ITEM 9.2.1.** If the internal temperature of the charger rises above 150 degrees Fahrenheit (°F), the charger will reduce its output current. When the internal temperature reaches 165°F, the charger will stop until the temperature drops below 165°F. If an external temperature probe is used and its temperature rises to 130°F, the output will be reduced. If the probe temperature reaches 135°F, the charger will stop until the temperature is reduced. When an external probe is not used, the charger will shut down earlier because of the higher ambient temperature inside of the charger.

4. RECEIVING AND INSTALLING THE CHARGER

Proper installation of the charger is important in order to achieve good charger performance and to prevent damage to the charger and batteries. When a charger is received, a check for possible in-transit damage should be made. If any damage is found, it should be reported as a claim to the carrier. To permit free air flow for convection cooling, allow three inches (3") minimum between the charger sides and other equipment and four inches (4") minimum on top of the charger.

!WARNING: THE CHARGER MUST BE PROGRAMMED FOR THE PROPER USER SPECIFICATIONS BEFORE THE INITIAL CHARGE IS STARTED.

!WARNING: NEVER PLACE ANYTHING ON TOP OF THE CHARGER WHILE OPERATING. DAMAGE TO THE CHARGER OR BATTERIES COULD OCCUR.

5. AC ELECTRICAL SUPPLY

Depending on the model, the charger must be connected to a single-phase, 60-100 Hertz AC power source, which can be either 115 or 230 volts.

Use an 8 or 10 AWG wire (model 12/201), 6 AWG wire (model 12/501), and 8 AWG wire (model 24/301) for the AC power input. Quarter-inch (¼") ring terminals are required for proper connection to the AC input and ground binding posts (A.A.R.). Remove the small door cover on the front of the charger by removing the two retaining screws. On the panel behind the binding posts is a diagram showing the proper jumper connections for the different AC voltages.

!WARNING: IMPROPER JUMPER CONNECTION MAY CAUSE SEVERE DAMAGE TO THE CHARGER AND THE BATTERY.

Configure the jumpers for your AC voltage source (refer to the jumper diagram below). Place the AC and grounding ring terminals on the binding posts and tighten the post nuts.

!WARNING: FAILURE TO PROPERLY CONNECT THE AC VOLTAGE CONDUCTORS COULD CAUSE SERIOUS DAMAGE TO THE CHARGER.

!WARNING: DO NOT OPERATE THE CHARGER WITHOUT PROPER GROUNDING. IMPROPER GROUNDING CAN RESULT IN THE RISK OF AN ELECTRIC SHOCK.

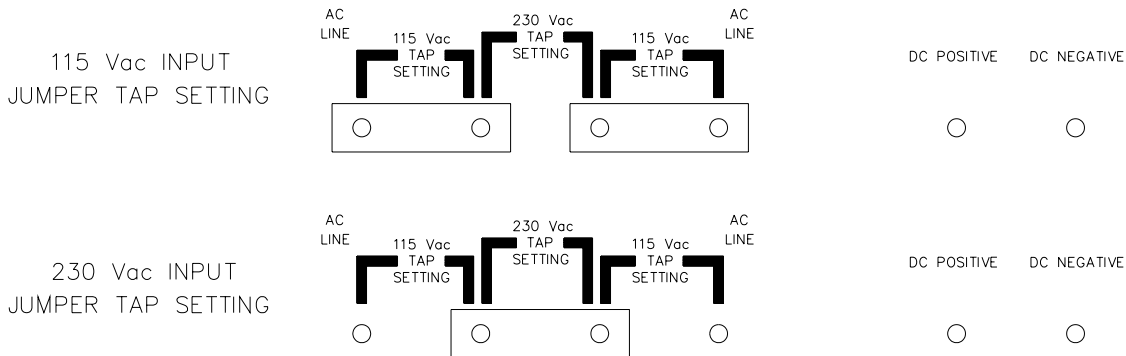

6. DC OUTPUT

The DC output wires are connected on the two right-most binding posts as labeled on the top of the charger (positive on the left and negative on the right). The DC cables should have quarter-inch (1/4") ring terminals for connecting them to the binding posts. Check to make sure the polarity of the DC output wires is the same as those connected to the battery. **WHEN CONNECTING THE DC WIRES TO THE CHARGER WITH THE AC POWER DISCONNECTED, A SPARK MAY OCCUR.** This is caused by the output capacitors being charged by the batteries. If the DC polarity is reversed, a circuit breaker will protect the charger from internal damage. Correct the reversed wires and push the circuit breaker button back in. Replace the door cover on the front of the charger after tightening all of the binding post nuts.

!WARNING: DO NOT TOUCH THE CHARGER'S TERMINALS OR AN ELECTRICAL SHOCK COULD OCCUR. A VOLTAGE IS PRESENT ON THE DC TERMINALS EVEN AFTER THE AC IS DISCONNECTED BECAUSE OF THE ENERGY STORED IN THE CAPACITOR.

7. TEMPERATURE PROBE

The external temperature probe is an optional way of extending battery life by using temperature compensation. One end of the temperature probe cable has a three-pin plug, which plugs into a

receptacle labeled TEMP PROBE on the front of the charger. The other end of the cable has the temperature sensor sealed either in a terminal or small metal box.

!WARNING: IT IS IMPORTANT TO MOUNT THE TEMPERATURE PROBE ON THE BATTERIES FOR PROPER TEMPERATURE COMPENSATION. IF THIS CANNOT BE DONE, LOCATE THE PROBE AS LOW AS POSSIBLE IN THE BUNGALOW OR CABINET.

Terminal-Type Probe

The terminal-type probe should be attached to the negative (-) battery post near the center of the battery pack. If the threaded stud is long enough above the battery jumper nut, attach the probe with another nut. Torque this nut to proper specifications. If the stud is too short, the nut holding the jumper wire will need to be removed. Open or remove the load and charging circuits to the batteries. Remove the nut holding the jumper and add the probe, then torque the nut to the proper specifications. Then close or connect the load and charging circuits back to the batteries.

Box-Type Probe

The metal box has a high performance contact adhesive tape for attaching it to the battery. To attach, clean a spot for the probe on the middle battery about three inches (3") down from the top of the battery. Make sure the spot is free of all dirt and oil or the probe will not adhere properly. For proper adhesion, the battery surface must be cleaned with

isopropyl alcohol. Ideal application temperature range is between 70 and 100°F. Initial application to surfaces at temperatures below 50°F is not recommended. Under cold conditions, the surface should be warmed before application. Once properly applied, low temperatures will not affect the bond strength.

Remove the adhesive's protective strip and press the probe firmly against the battery to ensure good adhesion.

Securely fasten the temperature probe cable to protect the probe from being torn from the battery. Secure the probe's cable to a fixed object to ensure the probe will not be pulled loose. Use a cable tie mount on the battery or on the adjacent battery, if necessary.

8. BATTERY SENSE CABLE

A unique feature of charger models 12/501 and 24/301 is that a battery sense cable may be used to monitor the battery voltage. This eliminates the problem of compensating for the voltage drop in the DC cord, thus delivering to the charger a more accurate voltage reading. Connect the red wire to the positive battery post and the black wire to the negative post. If more wire is required to reach the battery terminals, simply splice in more wire (22 AWG or larger). **BE SURE THE BATTERY SENSE CABLE IS DIRECTLY CONNECTED TO THE BATTERY POSTS.** If the battery sense cable is to be used, set Function 23 to "2".

 **WARNING: NEVER DISCONNECT THE BATTERY SENSE CABLE WHEN THE CHARGER IS OPERATING OR DAMAGE TO THE CHARGER COULD OCCUR.**

9. OPERATION

The battery charger is operated with the four buttons on the front of the charger. The buttons are used for two different modes of operation: DISPLAY FUNCTIONS and PROGRAMMING FUNCTIONS. The charger also has a three-digit display used for showing charge data and programming function values. If the charger is off (with AC power on), the entire display will blink. When the charger is on and none of the buttons are pressed for over one hour, the display will turn off except for a small dot in the lower right hand corner (see Function 14). If a problem is detected by the charger, the dot in the lower right hand corner will flash very fast. To stop this blinking, clear the error codes (see Function 17).

9.1 Display Functions

The labels on the right side of the buttons are for the display functions. When the charger is running and is not in the programming mode, pushing one of the buttons will display data about the charge cycle.

9.1.1 Voltage

When the voltage button is pressed and held, the display will read the voltage present at the charger terminals. If the button is pushed and released, it displays the voltage present at the battery terminals. The latter operation is in effect only if there are no errors and sample hold is set to 0 for model 12/201, and 0 or 2 for models 12/501 and 24/301 (see Function 23).

9.1.2 Current

Pressing the current button will display the current being provided by the charger to the load.

9.1.3 Temperature

When the temperature button is pressed and held, the display will show the internal temperature of the charger (Function 15). When the button is pressed and released (if an external temperature probe is used), the display will show the temperature of the batteries.

9.1.4 Start/Stop

The bottom button is the START/STOP button, which toggles the charger's output ON and OFF. If Function 18 is set ON (1), the stop switch cannot be used to turn off the charger's output. If the charger is OFF, the display flashes. The programming mode is accessible while the charger is OFF.

9.2 Programming Functions

To operate the battery charger in the programming mode, use the labels on the left side of the buttons. From the top down, the button functions are: UP, DOWN, CLEAR and ENTER. To use the programming mode, follow the steps below:

- (a) Press and hold the UP button in, then press and release, in order, the CLEAR, DOWN, and CLEAR buttons.

Response: The display will respond by showing "888".

- (b) Release the UP button, then press and release ENTER.

Response: The display will first show the EPROM revision number, then "..1" (the first function number) will be shown after the ENTER button is pressed and released.

- (c) Use the UP and DOWN buttons (function numbers move up or down in numerical order) to select the function that is to be executed or programmed. The display will show the function number, which moves once for each push of the UP or DOWN buttons. Holding the UP or

DOWN buttons will also advance through the functions. Press ENTER.

Response: The function will be executed and continue to display the function number or the display will show the present value in a programmable function.

(d) To change a programmable function (only Functions 8-11, 13-15, 18-20, and 22-26 may be programmed), press the UP and DOWN buttons until the new value desired is displayed. Press ENTER.

Response: The new value is stored in the charger's memory and the function number is displayed. If CLEAR is pressed, the new value is ignored and the function number is displayed.

(e) To exit programming, press CLEAR from the function selection mode. If the charger is left in programming for an extended period of time, it will automatically switch back to the display mode.

9.2.1 Function Descriptions

The descriptions below are given in the following order: function number, factory setting (if one is applicable), function name, and function definition.

1 DATE CODE

The EPROM date code is displayed as three numbers (month, date, and year) with this function.

2 DAYS FROM LAST POWER FAULT

This function is a counter which adds one every 24 hours and will reset to zero when the AC power is interrupted.

3 POWER FAULT COUNTER

Counts the total number of power outages. Whenever the charger is restarted and has run for 6 minutes, the power fault counter will increase by one. To reset the counter, either use Function 16 or the RESET function from a terminal (see Item 12).

4 MINIMUM INTERNAL CHARGER TEMPERATURE

This will display the lowest temperature recorded inside the charger since the last RESET was executed or since power-up.

5 MAXIMUM INTERNAL CHARGER TEMPERATURE

This displays the highest temperature recorded inside the charger since the last RESET was executed or since power-up.

6 MINIMUM BATTERY TEMPERATURE

This is displayed when an external temperature probe is connected. The value shown is the lowest temperature recorded for the battery since the last RESET was executed or since power-up.

7 MAXIMUM BATTERY TEMPERATURE

This is displayed when an external temperature probe is connected. The value shown is the highest temperature recorded for the battery since the last RESET was executed or since power-up.

8 "1" CELLS IN THE BATTERY

THE USER MUST SET THIS TO THE NUMBER OF CELLS IN THE BATTERY FOR THE CHARGER TO OPERATE PROPERLY. The battery cell range for models 12/201 and 12/501 is from 1 to 12 (for lead-acid, use 1 to 8). For model 24/301, the battery cell range is from 1 to 24 (for lead-acid, use 7 to 15, and for nickel cadmium, use 10 to 24). **BATTERY CELL SETTINGS FROM 1 TO 6 ARE NOT RECOMMENDED FOR NORMAL USE ON MODEL 24/301.** If the number of cells is set at or near the upper limit and the temperature is very low, the temperature compensation may cause the voltage to go over its limit causing an error (Function 10).

9 "1.00" FLOAT VOLTAGE PER CELL

The user must set this to the float voltage per cell for a battery temperature of 77°F (25°C). The range is from 1.00 to 3.00 volts. For gel electrolytic batteries, use a typical float voltage of "2.23". **THIS FUNCTION MUST BE SET FOR THE CHARGER TO OPERATE PROPERLY.**

10 "3.0" TEMPERATURE COMPENSATION

This function adjusts the output voltage of the charger depending on the temperature. The reference temperature for compensation is 77°F (25°C). If an external temperature probe is not used, the compensation will be based on the charger's internal temperature sensor. The compensation value is **NEGATIVE** because of the inverse relationship between the temperature and the voltage (as the temperature increases the voltage should decrease). The range is from "-9.9" to "0.0" mV/degree. Set the temperature compensation value to the battery manufacturer's specifications. When changing to degrees Centigrade (°C) (see Function 15), change the temperature compensation by the conversion factor 1.80 (Example: "-3.0" in degrees Fahrenheit equals "-5.4" in degrees Centigrade).

11 "1.0" MAXIMUM CURRENT

Set this function to the maximum current the charger should provide to the batteries (the range is from 1 to 20 amps for model 12/201, 1 to 50 amps for model 12/501, and 1 to 30 amps for model 24/301). **THIS FUNCTION MUST BE SET FOR THE CHARGER TO OPERATE PROPERLY.**

12 ERROR CODES

This function gives numbers that represent problems that have occurred with the charger. If a printer is connected to the charger, error messages will be printed. For a detailed explanation of the error messages, refer to Item 10. The error codes are:

- 0 NO ERRORS FOUND
- 1 IMPROPER OUTPUT
- 2 STUCK BUTTON
- 3 INTERNAL
- 4 DEFECTIVE EXTERNAL TEMPERATURE PROBE
- 5 DEFECTIVE INTERNAL TEMPERATURE PROBE
- 6 VOLTAGE SET OVER LIMIT
- 7 NOT USED
- 8 BATTERY OVER TEMPERATURE
- 9 CHARGER OVER TEMPERATURE
- 10 EXCESSIVE CABLE DROP
- 11 BATTERY SENSE CABLE (IF USED)
- 12 PROGRAMMING LOST

13 "1" EXTERNAL TEMPERATURE PROBE

If an external battery temperature probe is to be used for voltage compensation, set this option ON (1) (see Item 7). Set this option to OFF (0) if the voltage compensation is to be based on the charger's internal temperature sensor. If this option is selected without an external probe connected, the charger will respond with an error code.

14 "1" DISPLAY TIME OUT

Setting this option "ON" (1) turns the display off except for the decimal point in the lower right corner after one hour of inactivity. Pressing any display button will turn the display back on. Set this option "OFF" (0) to keep the display active at all times.

15 "0" TEMPERATURE SCALE

Set this function to ON (1) if you want the temperature display and the temperature compensation to be in degrees Centigrade (°C). When this function is OFF (0), the temperature is in degrees Fahrenheit (°F). **IF THIS OPTION IS SET TO 1, THE TEMPERATURE COMPENSATION (Function 10) HAS TO BE ADJUSTED OR BATTERY LIFE WILL SUFFER BECAUSE OF OVER- AND UNDER-CHARGING.**

16 RESET STATISTICAL DATA

This function resets all of the minimum and maximum temperature data and sets the power fault counter to zero. This is the same as the RESET function from a terminal.

17 CLEAR ALL ERRORS

This function will clear all of the error indicators. This is the same as the CLEAR function from a terminal.

18 "0" STOP SWITCH DISABLE

When set ON (1), pressing the STOP switch **WILL NOT** shut off the charger's output.

19 "0" PRINT INTERVAL

Setting this flag ON (1) changes the print interval to 15 minutes. Setting this flag to OFF (0) changes the print interval to one hour.

20 "0" LOG INTERVAL

Setting this flag ON (1) enters data into the data log every 15 minutes. Setting this flag OFF (0) changes the log interval to one hour.

21 DATA LOG DUMP

Selecting this function will dump the contents of the data log file to a printer (approximately 380 lines). The data log dump may be terminated by pressing and holding the CLEAR button until "8888" appears on the display or by striking any key on an attached terminal.

22 "0" BAUD RATE

When this function is ON (1), the communication baud rate is set to 1200. When the function is OFF (0), the baud rate is 300. This function affects both the printer and terminal baud rate.

23 "0" SAMPLE HOLD

When this function is set to 2 (on models 12/501 and 24/301 only), the battery voltage is measured through the battery sense cable. If the battery sense is not connected, error number 11 will occur. When this function is set to 0, the output voltage of the charger is sensed through the DC cables. The output is then compensated for the voltage drops which occur in the cables and the terminals. If the cable drop becomes excessive, sample hold will be disabled until the problem is corrected and the errors are cleared. Set this function to "1" to disable sample hold. Optimum operation occurs when the function is set to "2".

24 "0" SET PASSWORD

The charger may be used with a modem over the phone lines. To discourage unauthorized access, a simple password can be used (automatic entry into the terminal mode may be gained if the password is "0"). The password can only be changed with the charger's push buttons. The range of the password is from 0 to 255. When the charger requests the password, enter a number in the range from -9000 to -9255, where the last three digits are the ones selected from the front panel of the charger (see Item 12).

25 "-40.0" MINIMUM COMPENSATION
 TEMPERATURE

This function limits the temperature compensation at the value set so that the charger output voltage no longer changes at any temperature lower than the set value. This function has to be set along with the TEMPERATURE COMPENSATION (Function 10) and the TEMPERATURE SCALE FUNCTION (Function 15) values. The range is -40 to 140. If in °F or °C scale, set value accordingly.

26 "140.0" MAXIMUM COMPENSATION
 TEMPERATURE

This function limits the temperature compensation at the value set so that the charger output voltage no longer changes at any temperature higher than the set value. This function has to be set along with the TEMPERATURE COMPENSATION (Function 10) and the TEMPERATURE SCALE FUNCTION (Function 15) values. The range is -40 to 140. If in °F or °C scale, set value accordingly.

10. ERROR CODE DESCRIPTIONS

As described in Function 12, error codes are shown if a problem occurs which the charger recognizes. If more than one error occurs, a short pause will be taken between showing the error codes. To clear an error code, see Function 17. If an error has been cleared, but the problem still exists, the error will be detected again after leaving the program or terminal mode. An explanation of each error code is given below:

1 IMPROPER OUTPUT

The charger is unable to reach either the set output current or the set output voltage. It will also occur if the input line voltage drops too low to maintain proper output levels. Verify the charger's output setting, line voltages and battery voltages before clearing this error.

2 STUCK BUTTON

One of the buttons on the front of the charger is not working properly or one was pushed too soon after being powered up (wait 30 seconds). The charger will display "222" for a few moments showing it recognized a problem with one of the buttons. If the button cannot be made to work, the charger needs servicing.

3 INTERNAL

This occurs if the control module has an internal problem. The charger needs servicing.

4 DEFECTIVE EXTERNAL TEMPERATURE
 PROBE

The charger was either expecting a temperature probe to be connected to the front of the charger or a probe is connected and is operating improperly. If an external probe is not desired, turn OFF the external temperature probe option (see Function 13).

5 DEFECTIVE INTERNAL TEMPERATURE
 PROBE

The temperature probe internal to the charger is not operating properly. The charger will need to be serviced.

6 VOLTAGE SET OVER LIMIT

The voltage plateau has been set over the maximum level that the charger is capable of producing.

7 NOT USED

8 BATTERY OVER TEMPERATURE

This error occurs when the battery temperature reaches 130°F. To prevent damage to the batteries, the output of the charger is reduced until 135°F is reached. At 135°F, the output will stop until the temperature decreases.

9 CHARGER OVER TEMPERATURE

This error occurs when the charger's temperature reaches 150°F. At 150°F, the output will be reduced to protect the charger from damage. When 165°F is reached, the charger will stop until the temperature decreases.

10 EXCESSIVE CABLE DROP

The battery voltage measured at the charger's terminals has exceeded the voltage measured at the batteries by 4 volts. This indicates there may be a problem with the cables between the charger and the batteries or between the batteries. The charger can only measure this if sample hold is set to "0" (Function 23).

11 BATTERY SENSE CABLE

On models 12/501 and 24/301, when the battery sense is active and detects an improper output voltage, this error will occur and sample hold will switch to "0". This error also occurs if sample hold is set to "2" without a battery sense cable connected.

12 PROGRAMMING LOST

If this occurs, the charger sensed one of the function variables to be invalid and the charger will shut down. All of the functions will have to be reprogrammed, and the charger then restarted.

11. PRINTER OPTION

!WARNING: THE PRINTER OUTPUT IS NOT ISOLATED FROM THE BATTERY. THE PRINTER MUST BE ISOLATED FROM GROUND AND FROM THE BATTERY TERMINALS. USE AN AC GROUNDING ADAPTER, NUMBER GCL3-749.

With the RS-232 cable option, a printer can be connected to the charger (see Function 22 for the proper baud rate). If a printer is connected, the charger will print, at regular intervals of either 15 minutes or 1 hour (see Function 19), the charge data of the charger and the batteries. The charger data is printed horizontally in the following order:

1. NUMBER OF DAYS FROM LAST STARTUP
2. NUMBER OF HOURS FROM LAST STARTUP
3. BATTERY VOLTAGE AT THE BATTERY
4. BATTERY CURRENT
5. BATTERY TEMPERATURE
6. AMBIENT TEMPERATURE
7. OUTPUT VOLTAGE AT THE CHARGER

When an error occurs, the charger will print the error message and then print a line of charge data. The charge data is printed so the time of the error is recorded.

12. TERMINAL OPTION

A terminal may be connected either directly to the charger or through a modem so the charger can be operated and the status of the batteries and the charger can be determined from a remote location. When the programming mode is accessed through a terminal, the front panel buttons are disabled. Almost any terminal can be used to control the charger output or inquire about its status (Function 22).

!WARNING: THE TERMINAL OUTPUT IS NOT ISOLATED FROM THE BATTERY. THE TERMINAL OR MODEM MUST BE ISOLATED FROM GROUND AND FROM THE BATTERY TERMINALS. USE AN AC GROUNDING ADAPTER, NUMBER GCL3-749.

To get the attention of the charger from the terminal, press the return key. The charger will respond with:

OK >

After the OK message is given, the charger enters the monitor mode and is ready to receive commands. In the monitor mode, commands have to be in capital letters and followed by a carriage return. If the power is interrupted or if the charger is left in the monitor mode for over three minutes without issuing any commands, the charger will automatically exit the monitor mode.

If a password is used when entering the terminal mode (Function 24), the charger will respond with:

PASSWORD? >

At this point, you have about 20 seconds to enter the password before the charger returns to the print mode. From the factory, the password is set to "0" (this allows automatic entry into the monitor mode), but it may be changed using Function 24. When entering the password, enter -9xxx where xxx is the value that you inserted in Function 24. **THE NEGATIVE SIGN MUST BE INCLUDED.** If the charger accepts the password, an "OK" is printed. However, if an incorrect password is entered, the charger will return to the print mode. The available commands are:

?	Lists all of the available commands.
START	Starts the charger after the X command is given.
STOP	Stops the charger. The charger's output is terminated as soon as this command is given.
STATUS	Prints the function settings.
RESET	Resets the minimum and maximum temperature and the power fault counter.
CHANGE	Changes the present settings of the charger.
ERRORS	Shows all of the errors that have occurred.
CLEAR	Clears all of the errors.
DUMP	Dumps the data log from memory.
LOG-CLEAR	Erases the data log.
P	Prints the charging data.
X	Returns to print mode.

To change one of the function values, enter the CHANGE command. The charger will respond with the following (the values shown are examples only and may be different from your actual charger settings):

V	VOLTAGE PER CELL	2.23
N	NUMBER OF CELLS	16
T	TEMPERATURE COMPENSATION	3.0
Y	MIN COMPENSATION TEMP	-40
Z	MAX COMPENSATION TEMP	140
C	CURRENT LIMIT	20.0
D	DAY	123
H	HOUR	10.250
P	PRINT EVERY HOUR	
L	LOG EVERY HOUR	
E	EXTERNAL TEMPERATURE PROBE CONNECTED	
S	SAMPLE HOLD ON	
?	REPRINTS THE CHARGER SETTINGS	
X	EXIT CHANGE	

CHANGE WHAT ?

Select which item you wish to change by entering the letter in the first column. A carriage return is not needed after the letter. If the item to be changed does not require numeric entry, then selecting the item will change its state. If a numeric entry is required, the charger will request a NEW VALUE to be entered. After any item is changed, its new value is displayed. If a valid command is not entered in three minutes, the charger will return to the print mode. When entering data, the entries have to be scaled because decimal points are not allowed. Use the following guideline when entering data for each function:

VOLTAGE PER CELL, 1.00 TO 3.00 VOLTS

ENTER: 100 TO 300
NUMBER OF CELLS, 1 TO 12 CELLS (MODELS 12/201 AND 12/501)
ENTER: 1 TO 12
for lead-acid batteries, use 1 to 8
NUMBER OF CELLS, 1 TO 24 CELLS (MODEL 24/301)
ENTER: 1 TO 24
for lead-acid batteries, use 7 to 15
for nickel cadmium batteries, use 10 to 24
TEMPERATURE COMPENSATION, -9.9 TO 0.0 Mv/deg
ENTER: -99 TO 0
MINIMUM COMPENSATION TEMPERATURE, -40 TO 140
ENTER: -40 TO 140
MAXIMUM COMPENSATION TEMPERATURE, -40 TO 140
ENTER: -40 TO 140
CURRENT LIMIT, 1.0 TO 20.0 AMPS (MODEL 12/201)
ENTER: 10 TO 200
CURRENT LIMIT, 1.0 TO 50.0 AMPS (MODEL 12/501)
ENTER: 10 TO 500
CURRENT LIMIT, 1.0 TO 30.0 AMPS (MODEL 24/301)
ENTER: 10 TO 300
DAY, 0 TO 999
ENTER: 0 TO 999
HOUR, 0.000 TO 23.999
ENTER: 0 TO 23999

13. DATA LOG FILE

At regular intervals of either 15 minutes or 1 hour (see Function 20), the charger will store information into a data log file. Up to 384 records of information are saved and can be examined later. When the file is full, as new data comes in, the oldest data is erased. For example, if 1 hour is selected for the time interval, the charger will remember statistics for 16 days. Using the shorter time interval, only the last 4 days of charge data will be saved. This information is useful in monitoring the activity of the charger and the batteries. When an error occurs, it is also written into the data log file, followed by a line of charge data which specifies the time of the error.

A portable printer or terminal may be used to collect the data. The format of the data dump is the same as shown under item 11. If a printer is used, dump the data log file by executing Function 21. To stop the dump, press and hold the CLEAR button until "888" appears on the display. If a terminal is used,

select the DUMP command. Pressing any key on the terminal will stop the dump. When a terminal is used, the data log file may be downloaded to the terminal if it is set up to capture the data. The time it takes to dump a full file is approximately 13 minutes when the baud rate is set at 300. If the AC power is disconnected or interrupted, the data log file may contain random information.

14. MAINTENANCE

The battery charger requires minimal maintenance. It should be kept clean and all connections are to be tightly secured. In the event of an intermittent operation, examine and tighten, if necessary, all connections. **BE SURE THE CHASSIS IS SECURELY GROUNDED.** If any problem cannot be resolved, contact NATIONAL RAILWAY SUPPLY, INC.

15. SERVICING

If the battery charger operates improperly, check Function 12 for a possible error code number. Use the following steps when a problem occurs that is not recognized by the charger.

- a. Begin by pressing all four buttons of the front of the charger simultaneously. This resets the charger and may correct the problem.
- b. Check the circuit breaker to see if it has opened (popped out) and push it in to reset it if necessary.
- c. Next, remove the small cover on the front of the charger and make sure all of the binding post nuts are tight. Also, check the jumper tap configuration for the AC voltage used.
- d. Check the polarity between the DC output and the battery and make sure the connections are tight.
- e. If the steps above do not solve the problem, contact NATIONAL RAILWAY SUPPLY, INC.

16. CHARGER SPECIFICATIONS

Model	ERB-C 12/201	ERB-C 12/501	ERB-C 24/301
AC Input Voltage	115VAC (100-128) or 230VAC (200-256)		
AC Input Current (full power)			
115VAC	5.2 amps	14.6 amps	16.5 amps
230VAC	2.6 amps	7.8 amps	8.25 amps
AC Input Frequency	60 – 100 ± 5% Hertz (single-phase)		
AC Line Regulation	11.3% for 8 cells 19.5% for 7 cells 26.5% for 6 cells 34.7% for 5 cells 42.7% for 4 cells 46.5% for 3 cells 57.1% for 2 cells 58.2% for 1 cell	10% *	10% *
*indicates 2.00 volts/cell; all other 2.27 volts/cell (60 Hz) at rated current output			
AC Fuses	MDA 4 or equivalent	MDA 12 or equivalent	MDA 12 or equivalent
DC Output Voltage Maximum	22.5 volts	22.5	36.0 volts
DC Output Current Maximum	20 amps	50 amps	30 amps
DC Output Ripple (2.0 volts / cell)	1.4 Vp-p at 20 amps .3 Vp-p at 2 amps (2.27 v/cell)	1.0 Vp-p at 50 amps .15 Vp-p at 2 amps	1.2 Vp-p at 30 amps .25 Vp-p at 2 amps
Power Factor (2.0 volts / cell)	Percentage for High Rate at:		
	20 amps	50 amps	30 amps
	81.0 for 8 cells 76.0 for 7 cells 68.0 for 6 cells 62.0 for 5 cells 54.0 for 4 cells 57.0 for 3 cells 40.0 for 2 cells 34.0 for 1 cell	77.0 for 9 cells 70.0 for 8 cells 64.0 for 7 cells 57.0 for 6 cells 51.0 for 5 cells	79.0 for 18 cells 73.0 for 16 cells 66.0 for 14 cells 58.0 for 12 cells
Power Factor (2.23 volts/cell)	Percentage for Low Rate at:		
	2 amps	2 amps	2 amps
	- 24.0 for 8 cells - 24.0 for 7 cells - 21.0 for 6 cells - 19.0 for 5 cells - 17.0 for 4 cells - 16.0 for 3 cells - 14.0 for 2 cells - 12.0 for 1 cell	- 24.0 for 9 cells - 23.0 for 8 cells - 22.0 for 7 cells * - 21.0 for 6 cells - 20.0 for 5 cells * 2.0 volts/cell	- 68.0 for 18 cells - 67.0 for 16 cells - 66.0 for 14 cells - 64.0 for 12 cells
DC Output Regulation	Voltage: 1.0 - 20.0 volts ± 0.5% Current: 1.0 - 20.0 amps ± 0.5%	Voltage: 1.0 - 20.0 volts ± 0.5% Current: 1.0 - 50.0 amps ± 0.5%	Voltage: 10.0 - 36.0 volts ± 0.5% Current: 1.0 - 30.0 amps ± 0.5%
DC Output Cord Length	≤ 60 ft. - 8 AWG ≤ 40 ft. - 10 AWG	≤ 15 ft. - 6 AWG ≥ 15 ft. - Heavier	≤ 20 ft. - 8 AWG ≥ 20 ft. - Heavier
Weight, Net	26.2 lbs.	42.2 lbs.	44.3 lbs.

17. PARTS LIST

The following is a list of all the parts found in the NATIONAL RAILWAY SUPPLY, INC. BATTERY CHARGERS. When replacing a part, **use only original factory replacement parts** of the correct size and rating.

DESCRIPTION	ERB-C MODELS		
	12/201	12/501	24/301
TRANSFORMER ASSEMBLY	12275S	14305S	14330S
SCR ASSEMBLY	15909S	17181S	17011S
SHUNT ASSEMBLY	10734S	10734S	10734S
SHUNT INSULATOR	14136S	14136S	14136S
AC INPUT JUMPERS	14241S	14241S	14241S
CONTROL MODULE	16740S	16750S	16755S
BEZEL ASSEMBLY	14992S	14992S	14992S
TEMP TRANSDUCER, 10' (BOX W/ ADHESIVE)	14123S	14123S	14123S
TEMP TRANSDUCER, 30' (BOX W/ ADHESIVE)	14126S	14126S	14126S
TEMP TRANSDUCER, 10' (W/ TERMINAL)	29741S	29741S	29741S
TEMP TRANSDUCER, 30' (W/ TERMINAL)	29742S	29742S	29742S
CONTROL CABLE, J1	14103S	15326S	15326S
CONTROL CABLE, J2	14549S	15038S	15038S
PRINTER CABLE ASSEMBLY	14161S	14161S	14161S
OUTPUT CAP	14417S	15032S	15032S
BASE ASSEMBLY	21276S	21277S	21287S
COVER ASSEMBLY	14203S	15034S	15034S
DIODE ASSEMBLY, D	14786S	14786S	14786S
TERMINAL TAP STRIP	14484S	14484S	14484S
FUSEHOLDER, ASSEMBLY	03837S	03837S	03837S
VARISTOR ASSEMBLY W/ CAP., VR1	12717S	12717S	12717S
FUSE	15834S	15029S	15029S
TAP STRIP ASSEMBLY W/ I/O STUDS	14789S	14789S	14789S
CIRCUIT BREAKER ASSEMBLY	14092S	17243S	15037S
VARISTOR ASSEMBLY, VR2	14759S	14759S	14759S
BUSHINGS, 1" DIA (12)	14197S	14197S	14197S

The adhesive used on the temperature probes (#14123S and #14126S) is 3M Scotch #Y-9473 which is a thermally conducting two-sided adhesive tape. If a replacement adhesive is needed, use this type of tape or an equivalent adhesive.

18. WIRING DIAGRAM

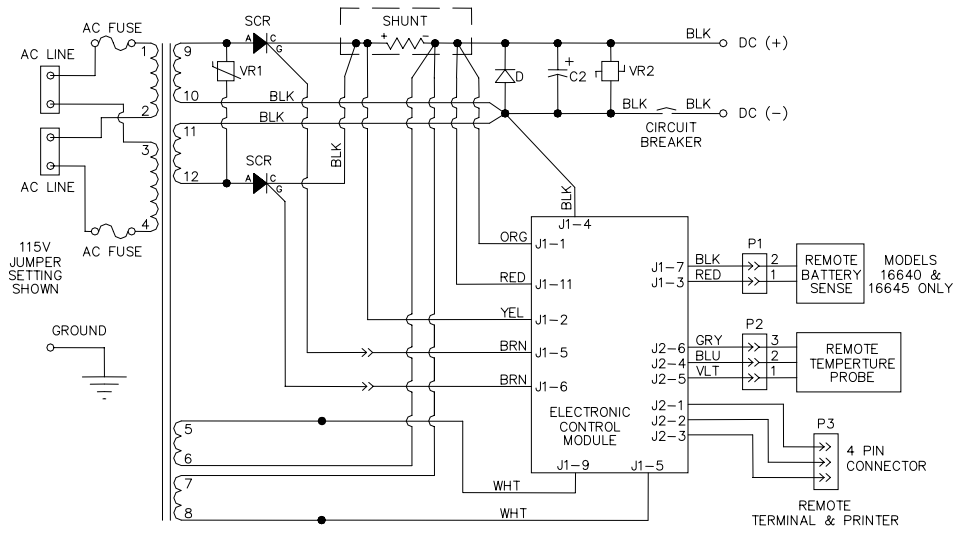

MODEL	AC FUSE SIZE
ERB-C 12/201	MDA-4
ERB-C 12/501	MDA-12
ERB-C 24/301	MDA-12

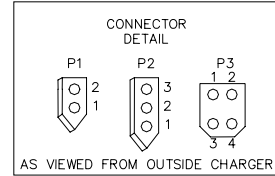

C2	OUTPUT CAPACITOR
D	DIODE ASSEMBLY
VR1	VARIATOR WITH CAP.
VR2	VARIATOR

01434WR_A1