

---

# **RACKMOUNT BATTERY CHARGERS**

## **ERB-C MODELS 12/20R, 12/20DR, 12/40R & 24/30R**

---

### **PLEASE SAVE THESE IMPORTANT SAFETY AND OPERATING INSTRUCTIONS**

For correct operation of the equipment, it is important to read and be familiar with this entire manual before installing and operating the charger.  
**DO NOT DISCARD THIS MANUAL AFTER READING.**



**LOOK FOR THIS SYMBOL TO POINT OUT SAFETY PRECAUTIONS. IT MEANS: BECOME ALERT—YOUR SAFETY IS INVOLVED. IF YOU DO NOT FOLLOW THESE SAFETY INSTRUCTIONS, INJURY OR PROPERTY DAMAGE CAN OCCUR.**

#### **1. IMPORTANT SAFETY INSTRUCTIONS**

- a. Before using the battery charger, read all the instructions and caution markings on the battery charger, the battery, and all of the products using the battery.
- b. Do not touch the uninsulated parts of the AC input or the DC wires, the charger's binding posts, or the battery terminals as there is a possibility of electrical shock.
- c. Batteries produce hydrogen gas while operating, which can explode if ignited. Never smoke, use an open flame, or create sparks in the vicinity of the battery. Ventilate the area well when the battery is charging in an enclosed area.
- d. Batteries contain caustic material which may cause burns. Do not get in eyes, on skin, or clothing. If the gelled or liquid content of the batteries contacts the skin or clothing, wash the area thoroughly with water. In the case of contact with the eyes, flush immediately with clean water for 15 minutes and obtain medical attention.
- e. Only qualified personnel should program or service this equipment.
- f. De-energize all AC and DC power connections before servicing this unit. If

injury does occur, apply standard treatment for electrical shock and, if necessary, consult with a physician.

- g. The charger is not for outdoor use. Do not expose the charger to rain or snow.
- h. Do not operate the charger if it has received a sharp blow, been dropped, or otherwise damaged.
- i. Do not disassemble the charger. Have the charger examined by a NATIONAL RAILWAY SUPPLY, INC. service agent. If the charger is reassembled incorrectly, damage to the charger and the batteries or an electrical shock may result.

#### **2. DESCRIPTION**

The NATIONAL RAILWAY SUPPLY, INC. battery charger is a convection-cooled, solid state, SCR regulated charger that provides either a constant current or constant voltage output. It is designed to make battery charging simple and has a variety of programmable options to personalize the charge profile. The charger can be programmed to charge batteries within a cell range of: 1 to 8 cells (Models 12/20R, 12/20DR and 12/40R) or 7 to 15 cells (Model 24/30R) for gel cell, liquid lead-acid, and valve-regulated batteries, and a cell range of 1 to 12

(Models 12/20R, 12/20DR and 12/40R) or 7 to 24 cells (Model 24/30R) for nickel cadmium and nickel iron batteries.

The charger has a comprehensive, self-checking diagnostic program to monitor the quality of charge and check its own safety conditions. A four-digit display will show charge data, the programmed charger settings, and error codes. These values are useful to monitor and correct problems, if needed, with the charging system and with the battery.

### 3. THEORY OF OPERATION

When the charger is connected to the desired AC voltage source (115 or 230), the transformer creates auxiliary voltages for the electronic control module. The electronic control module has a microprocessor, which controls and monitors the charger so it will perform properly. The transformer also supplies the power output used for charging the batteries and provides electrical isolation between the charger's output and the AC source.

The charger's output current flows through a shunt and is sensed by the electronic control module along with the charger's output voltage. These values are converted into drive pulses for the SCRs by the control module. This pulsating charge current (a pulse occurs each time an SCR is on) is then filtered by a large capacitor and the batteries to provide a smooth output.

The charger has an "IE" profile which is: (a) High rate constant current, and (b) Constant voltage. When the charger is first started, the SCRs will conduct for a certain portion of the sinusoidal anode voltage to provide the required charging current at the low level of battery voltage. In this start region, a constant current is applied to the battery. The SCR conduction will then increase as the battery voltage increases in order to provide a higher output voltage while maintaining a constant charging current.

When the battery voltage reaches the float voltage, the SCRs will start to decrease their output. This causes the charger to automatically change from a constant current charge region to a constant voltage charge region. As the batteries become fully charged, the output current decreases. A

continuous constant float voltage will be supplied to the batteries to maintain their charge.

The electronic control module also senses the internal components of the charger for any change in their performance. When an external temperature probe is not used, the charger's internal temperature sensor will be used for the temperature compensation (Functions 10 and 13). ALL REFERENCES TO FUNCTION NUMBERS ARE FOUND UNDER ITEM 9.2.1. If the internal temperature of the charger rises above 160 degrees Fahrenheit (°F), 71 degrees Centigrade (°C), the charger will reduce its output current. When the internal temperature reaches 170°F (77°C), the charger will stop until the temperature is reduced.

If an external temperature probe is used and its temperature rises to 140°F (60°C), the output will be reduced. If the probe temperature reaches 145°F (63°C), the charger will stop until the temperature is reduced.

### 4. RECEIVING AND INSTALLING THE CHARGER

Proper installation of the charger is important in order to achieve good charger performance and to prevent damage to the charger and batteries.

When a charger is received, a check for possible in-transit damage should be made. If any damage is found, it should be reported as a claim to the carrier. To permit free air flow for convection cooling, allow three inches (3") minimum between the charger sides and other equipment and four inches (4") minimum on top of the charger.

The charger has been designed to fit into a standard 19- or 23-inch rack mount unit. Brackets which attach the charger to the rack can be attached so the charger is either flush mounted or with a five-inch (5") offset. (See illustration following.)

 **WARNING: THE CHARGER MUST BE PROGRAMMED FOR THE PROPER USER SPECIFICATIONS BEFORE THE INITIAL CHARGE IS STARTED.**

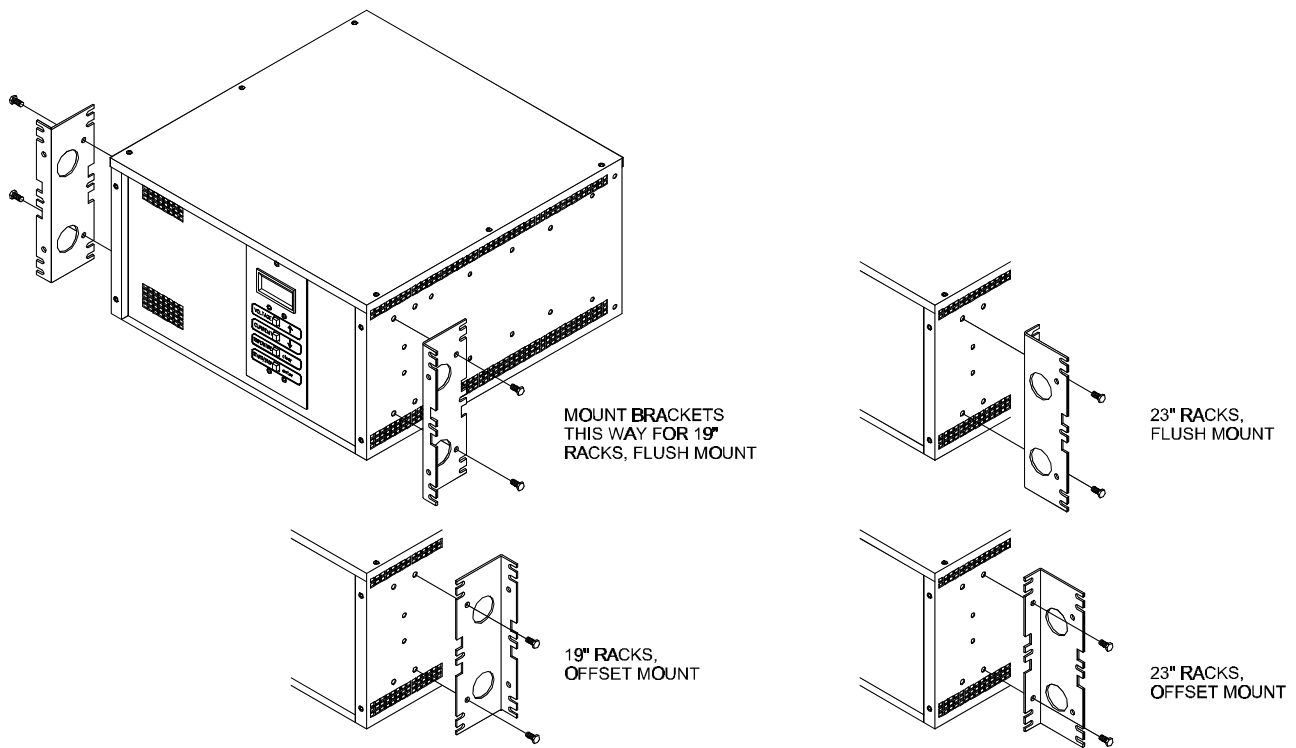

## 5. AC ELECTRICAL SUPPLY

The charger must be connected to a single-phase, 60-Hertz AC power source, which can be either 115 or 230 volts. Use an 8 or 10 AWG wire (Model 12/20R), 6 AWG wire (Models 12/20DR and 12/40R), and 8 AWG wire (Model 24/30R) for the AC power input. Quarter-inch (1/4") ring terminals are required for proper connection to the AC input and ground binding posts (A.A.R.) located on the back of the charger. Follow the labels above each connector to properly connect terminals to the charger. Place the AC and ground ring terminals on the binding posts and tighten the post nuts.

**⚠️ WARNING: FAILURE TO PROPERLY CONNECT THE AC VOLTAGE CONDUCTORS COULD CAUSE SERIOUS DAMAGE TO THE CHARGER.**

Select the desired input voltage by setting the AC voltage selector switch also located on the back of the charger.

**⚠️ WARNING: DO NOT OPERATE THE CHARGER WITHOUT PROPER GROUNDING. IMPROPER GROUNDING CAN RESULT IN THE RISK OF AN ELECTRIC SHOCK.**

## 6. DC OUTPUT

The DC output wires are connected on the two right-most binding posts as labeled on the top of the charger (positive on the right and negative on the left). The DC cables should have quarter-inch (1/4") ring terminals for connecting them to the binding posts. Check to make sure the polarity of the DC output wires is the same as those connected to the battery. **WHEN CONNECTING THE DC WIRES TO THE CHARGER WITH THE AC POWER DISCONNECTED, A SPARK MAY OCCUR.** This is caused by the output capacitors being charged by the batteries. The charger will not operate in a reversed polarity condition. If the DC polarity is reversed, a circuit breaker, located on the back of the charger, will protect the charger from internal damage. Correct the reversed wires and push the circuit breaker button back in.

**⚠️ WARNING: DO NOT TOUCH THE CHARGER'S TERMINALS OR AN ELECTRICAL SHOCK COULD OCCUR. A VOLTAGE IS PRESENT ON THE DC TERMINALS EVEN AFTER THE AC IS DISCONNECTED BECAUSE OF THE ENERGY STORED IN THE CAPACITOR.**

## 7. TEMPERATURE PROBE

The external temperature probe is an optional way of extending battery life by using temperature compensation. One end of the temperature probe cable has a three-pin plug, which plugs into a receptacle labeled TEMP PROBE on the rear of the charger. The other end of the cable has the temperature sensor sealed either in a terminal or small metal box.

**⚠ WARNING: IT IS IMPORTANT TO MOUNT THE TEMPERATURE PROBE ON THE BATTERIES FOR PROPER TEMPERATURE COMPENSATION. IF THIS CANNOT BE DONE, LOCATE THE PROBE AS LOW AS POSSIBLE IN THE BUNGALOW OR CABINET.**

### Terminal-Type Probe

The terminal-type probe should be attached to the negative (-) battery post near the center of the battery pack. If the threaded stud is long enough above the battery jumper nut, attach the probe with another nut. Torque this nut to proper specifications. If the stud is too short, the nut holding the jumper wire will need to be removed. Open or remove the load and charging circuits to the batteries. Remove the nut holding the jumper and add the probe, then torque the nut to the proper specifications. Then close or connect the load and charging circuits back to the batteries.

### Box-Type Probe

The metal box has a high performance contact adhesive tape for attaching it to the battery. To attach, clean a spot for the probe on the middle battery about three inches (3") down from the top of the battery. Make sure the spot is free of all dirt and oil or the probe will not adhere properly. For proper adhesion, the battery surface must be cleaned with isopropyl alcohol. Ideal application temperature range is between 70 and 100°F. Initial application to surfaces at temperatures below 50°F is not recommended. Under cold conditions, the surface should be warmed before application. Once properly applied, low temperatures will not affect the bond strength.

Remove the adhesive's protective strip and press the probe firmly against the battery to ensure good adhesion.

**Securely fasten the temperature probe cable to protect the probe from being torn from the battery.** Secure the probe's cable to a fixed object to ensure the probe will not be pulled loose. Use a cable tie mount on the battery or on the adjacent battery, if necessary.

The temperature probe will not be activated until Function 13 is set to a "1". Refer to Function 10 to set temperature compensation value.

## 8. BATTERY SENSE CABLE

A unique feature of this charger is that a battery sense cable may be used to monitor the battery voltage. This eliminates the problem of compensating for the voltage drop in the DC cord, thus delivering to the charger a more accurate voltage reading. One end of the battery sense cable has a two-pin plug, which connects into the back of the charger in a connector labeled BATTERY SENSE. The other end of the cable has a RED and BLACK wire which connects to the battery. Connect the RED wire to the positive battery post and the BLACK wire to the negative post. If more wire is required to reach the battery terminals, simply splice in more wire (22 AWG or larger). **BE SURE THE BATTERY SENSE CABLE IS DIRECTLY CONNECTED TO THE BATTERY POSTS.** If the battery sense cable is to be used, set Function 23 to "2".

**⚠ WARNING: NEVER DISCONNECT THE BATTERY SENSE CABLE WHEN THE CHARGER IS OPERATING OR DAMAGE TO THE CHARGER COULD OCCUR.**

## 9. OPERATION

The battery charger is operated with the four buttons on the front of the charger. The buttons are used for two different modes of operation: DISPLAY FUNCTIONS and PROGRAMMING FUNCTIONS. The charger also has a four-digit display used for showing charge data and programming function values.

When reference is given to a number or word which is displayed in this section, it will be shown in quotation marks as actually displayed.

If the charger is off (with AC power on), "OFF" will be displayed. If the charger detects a problem, "Erxx" will be displayed to let you know there is some kind of error condition (xx will be error code number).

### 9.1 Display Functions

The labels on the right side of the buttons are for the display functions. When the charger is running and is not in the Programming mode, pushing one of the buttons will display data about the charge cycle.

#### 9.1.1 Voltage

When the voltage button is pressed and held, the display will read the voltage present at the charger terminals. If the button is pushed and released, it

displays the voltage present at the battery terminals. The latter operation is in effect only if there are no errors and voltage compensation is set to "0" or "2" (Function 23).

### 9.1.2 Current

Pressing the current button will display the current being provided by the charger to the load.

### 9.1.3 Temperature

When the temperature button is pressed and held, the display will show the internal temperature of the charger (Function 15). When the button is pressed and released (if an external temperature probe is used), the display will show the temperature of the batteries.

### 9.1.4 Start/Stop

The bottom button is the Start/Stop button, which toggles the charger's output on and off. If Function 18 is set to "1", the stop switch cannot be used to turn off the charger's output. If the charger is stopped, "OFF" is periodically flashed on the display.

## 9.2 Programming Functions

A new, quick Programming mode has been added. This allows rapid access to the five programming functions used most often. Activated as the default from factory, only Functions 8, 9, 10, 11 and 17 are available. To deactivate the quick programming mode, while selecting functions, press and hold either the up or the down button for 15 seconds. Once deactivated, quick Programming mode will remain deactivated until Function 1 is selected.

To operate the battery charger in the Programming mode, use the labels on the left side of the buttons. From the top down, the button functions are: UP, DOWN, CLEAR and ENTER. To use the Programming mode, follow the steps below:

a. Press and hold the UP button in, then press and release, in order, the CLEAR, DOWN, and CLEAR buttons, then release the UP button.

Response: The display will respond by showing "F1", the first function number.

b. Use the UP and DOWN buttons (function numbers move up or down in numerical order) to select the function that is to be executed or programmed. Each push of the UP or DOWN button will select the next numerical function number. Holding in the UP or DOWN button will rapidly advance through the functions.

Response: The display will show the function numbers as you scan through them.

c. Press and release ENTER after selecting the proper function number.

Response: The function will be executed and continue to display the function number or the display will show the present value in a programmable function.

d. To change a programmable functions value (only Functions 8-11, 13-15, 18-20, and 22-40 may be programmed), press the UP and DOWN buttons until the new value you want is displayed. Press ENTER.

Response: The new value is stored in memory and the function number is displayed. If CLEAR is pressed, the new value is ignored and the function number is displayed.

e. To exit Programming, press CLEAR from the function selection mode. If the charger is left in Programming mode for over ten (10) minutes, it will automatically switch back to the display mode.

Response: After the Programming mode has been exited, if any values were changed, the display will go through a counting sequence while updating the permanent charger memory.

### 9.2.1 Function Descriptions

The descriptions below are given in the following order: function number, factory setting (if one is applicable), function name, and function definition.

#### 1 *VERSION CODE*

The charger's software version number is displayed and the charger is switched to quick Programming mode with this function.

#### 2 *DAYS FROM LAST POWER OUTAGE*

This function is a counter which adds one every 24 hours and will reset to zero when the AC power is interrupted.

#### 3 *POWER FAULT COUNTER*

Counts the total number of power outages. Whenever the charger is restarted and has run for an hour, the power fault counter will increase by one. To reset this counter, either use Function 16 or the RESET function from a terminal.

#### 4 *MINIMUM INTERNAL CHARGER TEMPERATURE*

This will display the lowest temperature recorded inside the charger since the last RESET was executed or since power-up.

#### 5 *MAXIMUM INTERNAL CHARGER TEMPERATURE*

This displays the highest temperature recorded inside the charger since the last RESET was executed or since power-up.

#### 6 *MINIMUM BATTERY TEMPERATURE*

This is displayed when an external temperature probe is connected. The value shown

is the lowest temperature recorded for the battery since the last RESET was executed or since power-up.

#### 7 *MAXIMUM BATTERY TEMPERATURE*

This is displayed when an external temperature probe is connected. The value shown is the highest temperature recorded for the battery since the last RESET was executed or since power-up.

#### 8 *"6 or 12" CELLS IN THE BATTERY*

THE USER MUST SET THIS TO THE NUMBER OF CELLS IN THE BATTERY FOR THE CHARGER TO OPERATE PROPERLY. The battery cell range for Models 12/20R, 12/20DR and 12/40R is from "1" to "12" (for lead-acid, use 1 to 8). CHARGER EFFICIENCY IS REDUCED WHEN THE BATTERY VOLTAGE IS SET UNDER EIGHT (8) VOLTS. For Model 24/30R, the battery cell range is from "7" to "24" (for lead-acid, use 7 to 15, and for nickel cadmium, use 10 to 24). If the number of cells is set at or near the upper limit and the temperature is very low, the temperature compensation may cause the voltage to go over its limit causing an error condition (Function 10).

#### 9 *"2.23" FLOAT VOLTAGE PER CELL*

The user must set this to the float voltage per cell for a battery temperature of 77°F (25°C). The range is from "1.00" to "3.00" volts. For gel electrolytic batteries, use a typical float voltage of "2.23". Set the value to the battery manufacturer's specifications. THIS FUNCTION MUST BE SET FOR THE CHARGER TO OPERATE PROPERLY.

#### 10 *"-3.0" TEMPERATURE COMPENSATION*

This function adjusts the output voltage of the charger depending on the temperature. The reference temperature for compensation is 77°F (25°C). If an external temperature probe is not used, the compensation will be based on the charger's internal temperature sensor. The compensation value is NEGATIVE because of the inverse relationship between the temperature and the voltage (as the temperature increases the voltage should decrease). Set the temperature compensation value to the battery manufacturer's specifications. The range is from "-9.9" to "0.0" mV/degree/cell. When changing to degrees Centigrade (°C) (Function 15), the temperature compensation value will change by the conversion factor 1.80.

Example: "-3.0" in °F equals "-5.4" in °C

#### 11 *MAXIMUM CURRENT*

Set this function to the maximum current the charger should provide to the batteries (the range is from "1.0" to "20.0" amps for Models 12/20R and 12/20DR, "1.0" to "40.0" amps for

Models 12/40R, and "1.0" to "30.0" amps for Model 24/30R, at 0.2 amp increments for all models). THIS FUNCTION MUST BE SET FOR THE CHARGER TO OPERATE PROPERLY.

#### 12 *ERROR CODES*

This function gives numbers that represent problems that have occurred with the charger. If a printer is connected to the charger, error messages will be printed. For a detailed explanation of the error messages, refer to Item 10. The error codes are:

- 0 NO ERRORS FOUND
- 1 IMPROPER OUTPUT
- 2 STUCK BUTTON
- 3 INTERNAL
- 4 DEFECTIVE EXTERNAL TEMPERATURE PROBE
- 5 DEFECTIVE INTERNAL TEMPERATURE PROBE
- 6 VOLTAGE SET OVER LIMIT
- 7 CHARGER IS WARM
- 8 BATTERY OVER TEMPERATURE
- 9 CHARGER OVER TEMPERATURE
- 10 EXCESSIVE CABLE DROP
- 11 BATTERY SENSE CABLE
- 12 PROGRAMMING LOST
- 13 LOST CALIBRATION DATA
- 14 BATTERY IS WARM
- 15 BATTERY IS VERY COLD
- 16 VOLTAGE OUTSIDE LIMITS

#### 13 *"1" TEMPERATURE SENSOR*

Set this option to "0" if the voltage compensation is to be based on the charger's internal temperature sensor. If an external battery temperature sensor is to be used for voltage compensation, set this option to "1". When set to "1" without an external sensor connected, the charger will respond with an error code. If this function is set to "2", temperature compensation will be disabled.

#### 14 *"OFF" DISPLAY TIME OUT*

Set this option "OFF" to keep the display active at all times. Setting this option "ON" turns the display off except for the decimal point in the lower right corner after one hour of inactivity. Pressing any display button will turn the display back on.

#### 15 *"0" TEMPERATURE UNITS*

When this function is "0", the temperature displayed and the temperature compensation value is in degrees Fahrenheit (°F). Setting this function to "1" will change the temperature displayed and the temperature compensation value to be in degrees Centigrade (°C). **The temperature compensation value (Function 10) will automatically be adjusted to reflect the temperature unit selected.**

## 16 RESET DATA

This function resets all of the minimum and maximum temperature data and sets the power fault counter to zero. This is the same as the RESET function from a terminal.

## 17 CLEAR ERRORS

This function will clear all of the error indicators. This is the same as the CLEAR function from a terminal.

## 18 "0" STOP SWITCH DISABLE

If this function is set to "0", the charger can be started and stopped from the front panel. When set to "1", pressing the STOP switch WILL NOT shut off the charger's output.

## 19 "60" PRINT INTERVAL

Set this function to the interval in minutes between printouts. Setting this option to "0" will disable the charger from printing to a printer. The range for this function is from "0" to "999".

## 20 "60" LOG INTERVAL

Set this function to the interval in minutes between writing entries into the log file. Setting this function to "0" will disable the charger from writing to the log file. The range for this function is from "0" to "999".

## 21 DATA LOG DUMP

Selecting this function will dump the contents of the data log file to a printer (approximately 400 lines). The data log dump may be terminated by pressing and holding the CLEAR button until "8888" appears on the display or by striking the ESC key on an attached terminal.

## 22 "9600" BAUD RATE

Set this function to the desired baud rate which affects using either an optional serial printer or terminal. Value baud rates are "300", "1200", "2400", "4800", or "9600".

## 23 "0" SAMPLE HOLD

When this function is set to "0", the output voltage of the charger is sensed through the DC cables. The output is then compensated for the voltage drops which occur in the cables and the terminals. If the cable drop becomes excessive, Error Code 10 will occur and this function will be disabled until the problem is corrected and the error cleared. Set this function to "1" if no voltage compensation of the cable drop is desired. When this function is set to "2", the battery voltage is measured through an external battery sense cable. If the battery sense is not connected, Error Code 11 will occur. Optimum operation occurs when an external battery sense cable is used and this function is set to "2".

## 24 "0" PASSWORD

The charger may be used with a modem over the phone lines or with a terminal. To discourage unauthorized access, a simple password can be used (automatic entry into the terminal mode may be gained if the password is "0"). The range of the password is from "0" to "9999" when entered from the front panel. An eight-digit alphanumeric number may be entered from a terminal to also set the password. To set the password from a terminal, use the following format (new = new password, old = old password): passwd new new. To change a password, use this format: passwd old new new. If an alphanumeric number or a number larger than "9999" is entered from a terminal, "----" will be displayed when this function is viewed from the front panel.

## 25 "0" LOCATION

This function lets you set a location code in the charger. This is very useful when multiple chargers are to be used over the phone lines. The range of the location code is from "0" to "9999" when entered from the front panel. An eight-digit alphanumeric number may be entered from a terminal which enables you to use a more descriptive location code. If an alphanumeric number or a number larger than "9999" is entered from a terminal, "----" will be displayed when this function is viewed from the front panel.

## 26 "ON" RELAY STATE

When this function is set to "OFF", the relay will drop out only when a fatal error occurs. If this function setting is "ON", the relay will dropout on any error the charger identifies. (See Section 10 for error code descriptions.)

## 27 "0" DATE FORMAT

If this function is set to "0", the date format for the printer and log files will be month/date/year. When this function is set to "1", the format will be year/month/date. Set this function to "2" if the desired date format is date/month/year.

## 28 "0.00" EQUALIZE VOLTS

Set this function to the desired voltage per cell above the set float voltage (Function 9) at a temperature of 77°F (25°C) for an equalize charge cycle. The range is from "0" to "0.50" volts.

## 29 "0.00" EQUALIZE TIME

This function is the amount of time in hours that an equalize charge cycle will run. Setting this function to "0" will disable equalize charges. The range for this function is from "0" to "25.5" hours.

## 30 "0" EQUALIZE INTERVAL

Set this function to the number of days between equalize cycles. The range is from "0" to

"60" days. Setting this function to zero (0) will disable equalize charges. See Function 36 to begin first cycle.

**31 MONTH / DATE**

Use this function to set the present month and day so all entries in the log file or on printouts will have the accurate date information. The first two digits are used to set the month and the last two digits are to set the date. The range is from "01.01" to "12.31".

**32 TIME**

The correct time of day in minutes is set using this function. The format for this function is in 24-hour format so the range is from "00.00" to "23.59".

**33 YEAR**

Set this function to the present year so all entries in the log file or on printouts will have the accurate year information.

**34 "1.00" MINIMUM VOLTAGE**

Set this function to the minimum voltage per cell desired for the battery. If the battery voltage decreases below this level, an error will occur. The range for this function is from "0.2" to "3.00".

**35 "3.00" MAXIMUM VOLTAGE**

Set this function to the maximum voltage per cell desired for the battery. If the battery voltage increases above this level, an error will occur. The range for this function is from "1.00" to "3.00".

**36 "0.00" EQUALIZE START**

This function is the number of hours until the next equalize charge is started. Setting this function to "0.0" will start an equalize cycle now. The range for this function is from "0" to "999.9" hours. Once this cycle is completed, the charger defaults to the equalize interval set in Function 30.

**37 FACTORY USE ONLY. DO NOT USE.**

**38 "-40.0" MINIMUM TEMPERATURE**

Set this function to the minimum temperature at which the battery will operate. If the temperature drops below this temperature, an error will occur. If the temperature drops 9°F (5°C) below this point, output power is reduced to prevent battery destruction. This function applies only when Function 13 is set to "1".

**39 "32.0" MINIMUM TC TEMPERATURE**

Set this function to limit the lower temperature range for temperature compensation. If the temperature drops below this point, the output voltage is not increased any further. Default value is 32.0°(0°C).

**40 "95.0" MAXIMUM TC TEMPERATURE**

Set this function to limit the upper temperature range for temperature compensation. If the temperature exceeds this point, the output voltage is not decreased any further. Default value is 95.0°(35°C).

**41 "0" LOW CURRENT TRIP POINT**

Set this function to the low current value for the relay contacts on the charger to switch from normally closed (N/C) to normally open (N/O) for current monitor use. Set to zero to disable this function. The ranges are from "0.0" to "20.0" amps for Models 12/20R and 12/20DR, "0.0" to "40.0" amps for Model 12/40R, and "0.0" to "30.0" amps for Model 24/30R, at 0.2 amp increments for all models.

**42 "0" LOW VOLTAGE EQUALIZE TRIP POINT**

Set this function to the desired low voltage per cell on the battery that the charger monitors after AC power-up to determine if an equalize charge cycle is required. If the battery voltage is below this point, and the equalize functions are enabled, the charger will automatically start an equalize cycle after AC power-up. Functions 28 and 29 have to be set for this function to be performed. The range is from "0.00" to "2.55" volts per cell.

**10. ERROR CODE DESCRIPTIONS**

The message "Erxx" is displayed when the charger recognizes a problem has occurred, where xx is the error code number which the charger has recognized. If more than one error occurs, a short pause will be taken between showing of the error code numbers. To clear an error code, see Function 17. If an error has been cleared, but the problem still exists, the error will be detected again after leaving the program or terminal mode.

Some of the errors the charger detects are more serious than others. When a fatal error occurs, the charger will shut off to avoid possible further damage to the charger or batteries. A relay integrated into the charger switches states (on all errors or only on fatal errors as determined by Function 26) to let you know when an error has occurred.

The error code descriptions are given below in the following order:

- error code number
- fatal error status (NF = non-fatal; F = fatal),
- error code name, and
- error code definition

**1 (F) IMPROPER OUTPUT**

The charger is unable to reach either the set output current or the set output voltage. It will also occur if the input line voltage drops too low to maintain proper output levels. Verify the charger's output setting, line voltages and battery voltages before clearing this error.

## 2 (NF) STUCK BUTTON

One of the buttons on the front of the charger is not working properly. If the button cannot be made to work, the charger needs servicing.

## 3 (F) INTERNAL

This occurs if the control module has an internal problem. The charger needs servicing.

## 4 (NF) DEFECTIVE EXTERNAL TEMPERATURE PROBE

The charger was either expecting a temperature probe to be connected to the front of the charger or a probe is connected and is operating improperly. If an external probe is not desired, set the external temperature probe option (Function 13) to "0".

## 5 (NF) DEFECTIVE INTERNAL TEMPERATURE PROBE

The temperature probe internal to the charger is not operating properly. The charger will need to be serviced.

## 6 (F) VOLTAGE SET OVER LIMIT

The voltage plateau has been set over the maximum level that the charger is capable of producing.

## 7 (NF) CHARGER IS WARM

This error occurs when the charger's internal temperature reaches 160°F (71°C) to prevent damage to the charger.

## 8 (NF) BATTERY OVER TEMPERATURE

This error occurs when the battery temperature reaches 145°F (63°C). At 140°F (60°C), the output of the charger is reduced to protect the battery from damage (Error Code 14), but when 145°F (63°C) is reached, the charger will stop until the temperature decreases. This function applies only when an external temperature probe is in use.

## 9 (NF) CHARGER OVER TEMPERATURE

This error occurs when the charger's temperature reaches 170°F (77°C). At 160°F (71°C), the output of the charger is reduced to protect the battery from damage (Error Code 7), but when 170°F (77°C) is reached, the charger will stop until the temperature decreases.

## 10 (NF) EXCESSIVE CABLE DROP

The battery voltage measured at the charger's terminals has exceeded the voltage measured at the batteries by 4 volts. This indicates there may be a

problem with the cables between the charger and the batteries or between the batteries. The charger can only measure this if sample hold is set to "0" (Function 23).

## 11 (NF) BATTERY SENSE CABLE

When the battery sense is active and detects an improper output voltage, this error will occur and sample hold will switch to "1". This error also occurs if sample hold is set to "2" without a battery sense cable connected.

## 12 (F) PROGRAMMING LOST

If this occurs, the charger senses one of the function variables to be invalid and the charger will shut down. All of the functions will have to be reprogrammed, and the charger then restarted.

## 13 (F) CALIBRATION LOST

This occurs when the charger sensed a problem with the electronic control module. If this occurs, the charger will need to be repaired.

## 14 (NF) BATTERY IS WARM

This error occurs when the battery temperature reaches 140°F (60°C) to prevent damage to the batteries. This function applies only when an external temperature probe is in use.

## 15 (NF) BATTERY IS VERY COLD

This error occurs when the battery temperature reaches the value set in Function 38 to prevent damage to the batteries. When this occurs, the charger will output low current to the batteries to warm them up slowly, to help prevent battery breakdown.

## 16 (NF) VOLTAGE OUTSIDE LIMITS

If the battery voltage is sensed to be either higher or lower than the limits set with Functions 34 and 35, this error will occur.

## 11. PRINTER OPTION

With the RS-232 cable option, a serial printer can be connected to the charger (Function 22 sets the proper baud rate). One end of the printer cable has a four-pin plug, which connects into the front of the charger in a connector labeled MODEM. If a printer is connected, the charger will print at regular intervals (set with Function 19 or with PRINT command from a terminal) the charge data of the charger and the batteries. When an error occurs, the charger will also print the error message. The charge data is printed horizontally in the following order:

DATE OF PRINT LINE  
TIME OF THE PRINT LINE  
VOLTAGE AT THE CHARGER  
VOLTAGE AT THE BATTERY USING BATTERY SENSE

CABLE VOLTAGE USING SAMPLE AND HOLD  
 BATTERY CURRENT  
 BATTERY TEMPERATURE  
 CHARGER TEMPERATURE  
 CHARGER STATUS (ON OR OFF)

## 12. TERMINAL OPTION

A terminal may be connected either directly to the charger or through a modem so the charger can be operated and the status of the batteries and the charger can be determined from a remote location. One end of the terminal cable has a four-pin plug, which connects into the front of the charger in a connection labeled MODEM. Almost any terminal can be used to control the charger output or inquire about its status (Function 22).

When a terminal is connected, it is in the print mode. Charge data information from the charger is displayed on the terminal at regular intervals as set with Function 19. To enter the terminal mode of operation, press the return key on the terminal. While in the terminal mode, the automatic charge data displayed is disabled. After the return key is pressed, the charger will respond with a prompt which has the present time of day:

hrs:min:sec >

The charger is now ready to receive commands from the terminal. If the power is interrupted or if the charger is left in the monitor mode for over 10 minutes without issuing any commands, the charger will automatically exit the monitor mode. If a password is used when entering the terminal mode (Function 24), the charger will respond with:

password >

At this point, enter the password, which allows you entrance into the monitor mode. From the factory, the password is set to "0" (this allows automatic entry into the monitor mode), but it may be changed using Function 24 or with the PASSWD command (see below). If the charger accepts the password, an "OK" and then the prompt are displayed. However, if an incorrect password is entered, the charger will remain in the print mode. The available commands are:

.	Displays the present charge data
?	Lists all of the available commands
AMP	Sets the maximum output current (Function 11)
CELLCOUNT	Sets the number of battery cells (Function 8)
CELLVOLTS	Sets the battery float voltage (Function 9)
CLEAR	Clears all of the errors (Function 17)
CLRLOG	Erases the data log file
COLD	Sets minimum battery temperature (Function 38)
DATE	Sets the month date and year (Functions 31 & 33)
DUMP	Dumps data log file to the terminal (Function 21)
EQINTERVAL	Sets interval between equalize charge (Function 30)
EQLV	Sets the low voltage equalize trip point (Function 42)

EQSTART	Sets the time until the next equalize charge (Function 36)
EQTIME	Set the length of an equalize charge (Function 29)
EQVOLTS	Sets the equalize charge voltage level (Function 28)
ERRORS	Shows all errors which have occurred (Function 12)
EXIT	Returns to print mode
FORMATD	Sets the date format (Function 27)
LATP	Sets the low current trip point (Function 41)
LOCATION	Sets the location code of the charger (Function 25)
LOG	Sets the data log interval (Function 20)
PASSWD	Sets the terminal password (Function 24)
PRINT	Sets the print interval (Function 19)
QUIT	Returns to print mode
REGULATION	Sets type of sample hold (Function 23)
RELAY	Sets the relay error code status (Function 26)
RESET	Resets minimum and maximum data (Function 16)
START	Starts the charger
STATUS	Displays the present status of the charger
STOP	Stops the charger
SWITCH	Sets the stop switch disable (Function 18)
TCMAX	Sets the upper temperature range for temperature compensation (Function 40)
TCMIN	Sets the lower temperature range for temperature compensation (Function 39)
TEMPCOMP	Sets the temperature compensation (Function 10)
TEMPPROBE	Sets the type of temperature sensor (Function 13)
TEMPUNIT	Sets the temperature unit, °F or °C (Function 15)
TIME	Sets the present time of day (Function 32)
VARS	Displays the changeable function settings
VER	Displays the software version number (Function 1)
VOLTHIGH	Sets maximum battery voltage allowed (Function 35)
VOLTLOW	Sets minimum battery voltage allowed (Function 34)

In the monitor mode, commands can be entered in either upper or lower case and must be followed by a carriage return. When a command is entered, the present value or state of that function is displayed. To change a function to a different value, type in the command followed by a space and then the new value, or follow the format shown on the display. After any item is changed, its new value is displayed. If a valid command is not entered in 10 minutes, the charger will return to the print mode. When the monitor mode is exited, a short waiting period is required to save the variables that have been changed.

## 13. DATA LOG FILE

At regular intervals (set with Function 20 from front panel or with LOG command from a terminal), the charger will store information into a data log file. Up to 400 records of information are saved and can be examined later. When the file is full, as new data comes in, the oldest data is erased. For example, if

60 minutes is selected for the time interval, the charger will remember statistics for just over 16 days. This information is useful in monitoring the activity of the charger and the batteries. When an error occurs, it is also written into the data log file.

A portable printer or terminal may be used to collect the data. The format of the data dump is similar to item 11. If a printer is used, dump the data log file by executing Function 21. To stop the dump, press and hold the CLEAR button until "8888" appears on the display. If a terminal is used, select the DUMP command. Pressing the ESC key on the terminal will stop the dump. When a terminal is used, the data log file may be saved if the terminal is set up to capture the data. If the AC power is disconnected or interrupted for several days, the data log file may contain random information.

#### **14. MAINTENANCE**

The battery charger requires minimal maintenance. It should be kept clean and all connections are to be tightly secured. In the event of an intermittent operation, examine and tighten, if necessary, all connections. **BE SURE THE CHASSIS IS SECURELY GROUNDED.** If any problem cannot

be resolved, contact NATIONAL RAILWAY SUPPLY, INC.

#### **15. SERVICING**

If the battery charger operates improperly, check Function 12 for possible error code numbers. Use the following steps when a problem occurs that is not recognized by the charger.

- a. Begin by pressing all four buttons of the front of the charger simultaneously. This resets the charger and may correct the problem.
- b. Check the circuit breaker to see if it has opened (popped out) and push it in to reset it, if necessary.
- c. Next, check to make sure all of the binding post nuts are tightened. Also check for proper AC voltage switch selection.
- d. Check the polarity between the DC output and the battery and make sure the connections are tight.
- e. If following the steps above does not solve the problem, contact NATIONAL RAILWAY SUPPLY, INC.

## 16. CHARGER SPECIFICATIONS

Model	ERB-C 12/20R	ERB-C 24/30R	ERB-C 12/40R	ERB-C 12/20DR
<b>AC Input Voltage</b>	115 VAC (100-128) or 230 VAC (200-256)			
<b>AC Input Current</b> (full power)	5.3 amps for 115 VAC 2.3 amps for 230 VAC	16.4 amps for 115 VAC 7.6 amps for 230 VAC	13.5 amps for 115 VAC 5.3 amps for 230 VAC	12.1 amps for 115 VAC 5.1 amps for 230 VAC
<b>AC Input Frequency</b>	48-62 Hertz (single-phase)			
<b>AC Line Regulation</b> (for a constant output current at 2.27 volts/cell)	+ 25.5% for 6 cells + 8.7% for 8 cells	21.6% for 12 cells 4.7% for 16 cells	+ 31.6% for 6 cells + 13.0% for 8 cells	+25.5% for 6 cells +8.7% for 8 cells
<b>AC Fuses</b>	MDA 4 or equivalent	MDA 12 or equivalent	MDA 10 or equivalent	MDA 4 or equivalent
<b>Power Factor</b>	At 20 amps DC current 0.80 @ 230 VAC and 0.61 @ 115 VAC at 14.0 volts 0.90 @ 230 VAC and 0.76 @ 115 VAC at 18.0 volts	At 30.0 amps DC current 0.65 @ 230 VAC and 0.60 @ 115 VAC at 28.0 volts 0.81 @ 230 VAC and 0.76 @ 115 VAC at 36.0 volts	At 40.0 amps DC current 0.68 @ 230 VAC and 0.58 @ 115 VAC at 14.0 volts 0.83 @ 230 VAC and 0.74 @ 115 VAC at 18.0 volts	At 20.0 amps DC current 0.64 @ 230 VAC and 0.55 @ 115 VAC at 14.0 volts 0.82 @ 230 VAC and 0.74 @ 115 VAC 15 18.0 volts
<b>DC Output</b> Voltage Range:  Current Maximum:	2.0-20.0 volts ± .5% of rated voltage  20.0 amps ± 1% of rated current	2.0-36.0 volts ± .5% of rated voltage  30.0 amps ± 1% of rated current	2.0-20.0 volts ± .5% of rated voltage  40.0 amps ± 1% of rated current	2.0-20.0 volts ± .5% of rated voltage  20.0 amps ± 1% of rated current
<b>DC Output Ripple</b>	0.15 Vp-p at 20.0 amps, 12.0 volts  0.036 Vp-p at 2.0 amps, 12.0 volts	0.23 Vp-p at 30.0 amps, 24.0 volts  0.033 Vp-p at 2.0 amps, 24.0 volts	0.30 Vp-p at 40.0 amps, 12.0 volts  0.036 Vp-p at 2.0 amps, 12.0 volts	0.15 Vp-p at 20.0 amps, 24.0 volts  0.036 Vp-p at 2.0 amps, 12.0 volts
<b>Temperature Compensation</b>	-3.0 mV per ° per cell			
<b>Remote Relay Output</b>	Dry Contact Limit: 1 amp 30 VDC .5 amp 120 VAC			
<b>Weight, Net</b>	48.7 lbs.	67.0 lbs.	62.0 lbs.	72.0 lbs.

## 17. PARTS LIST

The following is a list of all the parts found in the NATIONAL RAILWAY SUPPLY, INC. battery chargers. When replacing a part, **use only original factory replacement parts** of the correct size and rating.

PARTS	ERB-C MODEL			
	12/20R	12/40R	24/30R	12/20DR
TRANSFORMER ASSEMBLY	16445S	16860S	16855S	16445S
CASE ASSEMBLY	22012S	22526S	22527S	22528S
SCR ASSEMBLY	22482S	22482S	22482S	22482S
SHUNT ASSEMBLY	18696S	18696S	18696S	18696S
CONTROLLER KIT	29562S	29536S	29538S	29562S
BEZEL ASSEMBLY	18278S	18278S	18278S	18278S
TEMP TRANSDUCER, 10' (BOX W/ ADHESIVE)	14123S	14123S	14123S	14123S
TEMP TRANSDUCER, 30' (BOX W/ ADHESIVE)	14126S	14126S	14126S	14126S
TEMP TRANSDUCER, 10' (W/ TERMINAL)	29741S	29741S	29741S	29741S
TEMP TRANSDUCER, 30' (W/ TERMINAL)	29742S	29742S	29742S	29742S
CONTROL CABLE, J1	21164S	21164S	21164S	21164S
CONTROL CABLE, J2	21186S	21186S	21186S	21186S
CAPACITOR, C1	02026S	02026S	02026S	02026S
CAPACITOR, C2 & C3	22483S	22483S	22483S	22483S
BASE, CASE	19789S	19789S	19789S	19789S
DIODE ASSEMBLY, D	14786S	14786S	17486S	14786S
FUSEHOLDER, F1	22479S	22479S	22479S	22479S
FUSEHOLDER, F2	22481S	22481S	22481S	22481S
VARISTOR ASSEMBLY	14759S	14759S	14759S	14759S
FUSE	15834S	15028S	15029S	15834S
CIRCUIT BREAKER ASSEMBLY	21177S	21539S	21659S	21177S
BRACKET, MOUNTING BASE, 19" or 23"	19793S	19793S	19793S	19793S
SWITCH ASSEMBLY	21441S	21441S	21441S	21166S
CORE, FERRITE BEAD, OVAL	18599S	18599S	18599S	18599S
WIRE ASSEMBLY, BEAD ASSEMBLY	21172S	21172S	21172S	21172S
WIRE ASSEMBLY, TRANS TO DC	21173S	21541S	21541S	21173S
WIRE ASSEMBLY, CIRCUIT BREAKER TO DC+	21176S	21542S	21658S	21176S
PANEL ASSEMBLY, FUSE/SWITCH	21442S	21544S	21663S	21182S
PANEL ASSEMBLY, HEATSINK MOUNTING	21447S	21546S	21662S	21187S
HEATSINK	14104S	14964S	14964S	14104S
KIT, CONNECTOR	14556S	14556S	14556S	14556S
CABLE, REMOTE VOLTAGE SENSE, 10'	15369S	15369S	15369S	15369S
CABLE, REMOTE VOLTAGE SENSE, 30'	24584S	24584S	24584S	24584S
RESISTOR ASSEMBLY	30786S	30786S	30786S	30786S

The adhesive used on the temperature probes (#14123S and #14126S) is 3M Scotch #Y-9473, which is a thermally conducting, two-sided adhesive tape. If a replacement adhesive is needed, use this type of tape or an equivalent adhesive.

# 18. WIRING DIAGRAM FOR MODELS 12/20R, 12/40R, 24/30R

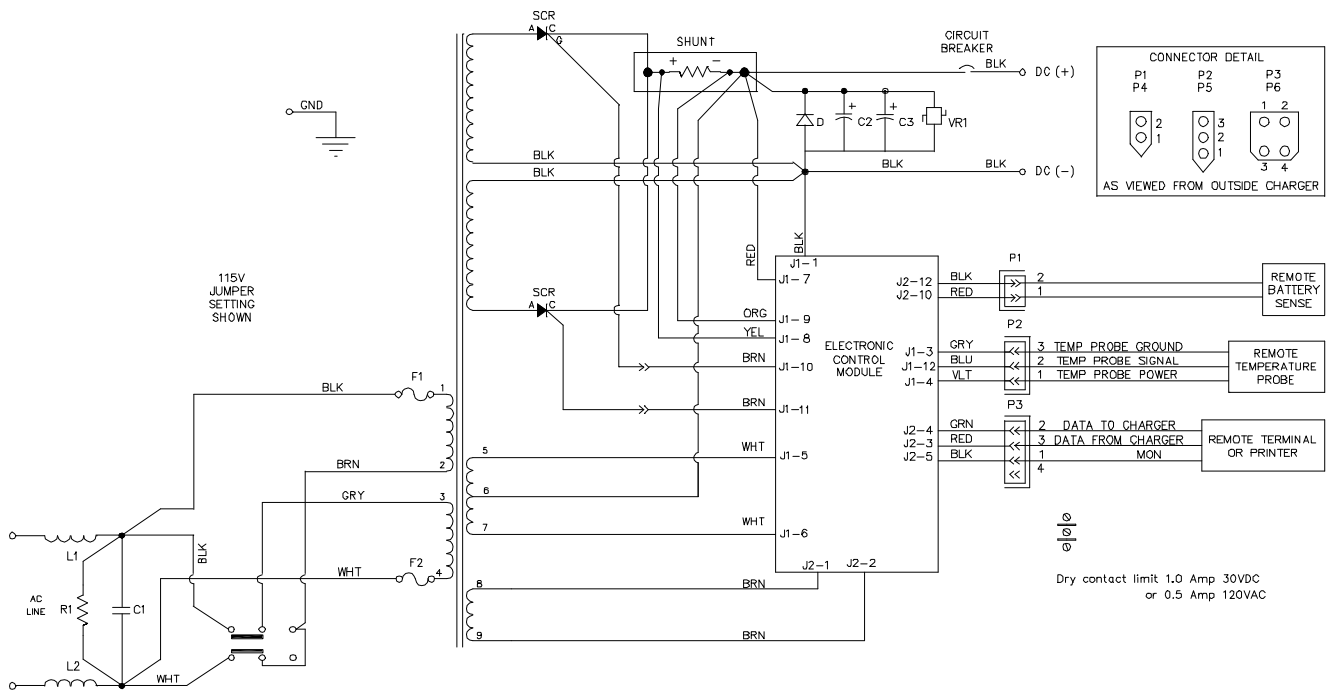

# 19. WIRING DIAGRAM FOR MODEL 12/20DR

