



**NATIONAL  
RAILWAY  
SUPPLY, INC.**

Installing, Operating and  
Service Instructions for the  
120/6 Solid State Charger

---

# MODEL ELC-120/6 BATTERY CHARGER and BATTERY PACK

---

## PLEASE SAVE THESE IMPORTANT SAFETY AND OPERATING INSTRUCTIONS

For correct operation of the equipment, it is important to read and be familiar with this entire manual before installing and operating the charger.  
**DO NOT DISCARD THIS MANUAL AFTER READING.**



**LOOK FOR THIS SYMBOL TO POINT OUT SAFETY PRECAUTIONS. IT MEANS: BECOME ALERT—YOUR SAFETY IS INVOLVED. IF YOU DO NOT FOLLOW THESE SAFETY INSTRUCTIONS, INJURY OR PROPERTY DAMAGE CAN OCCUR.**

### 1. IMPORTANT SAFETY INSTRUCTIONS

- a. Before using the battery charger, read all the instructions and caution markings on the battery charger, the battery, and all of the products using the battery.
- b. Do not touch the uninsulated parts of the AC input or the DC wires, the charger's binding posts, or the battery terminals, as there is a possibility of electrical shock.
- c. Batteries produce hydrogen gas while operating, which can explode if ignited. Never smoke, use an open flame, or create sparks in the vicinity of the battery. Ventilate the area well when the battery is charging in an enclosed area.
- d. Batteries contain caustic material, which may cause burns. Do not get in eyes, on skin, or clothing. If the gelled or liquid content of the batteries contacts the skin or clothing, wash the area thoroughly with water. In the case of contact with the eyes, flush immediately with clean water for 15 minutes and obtain medical attention.
- e. Only qualified personnel should program or service this equipment.
- f. De-energize all AC and DC power connections before servicing this unit. If injury does occur, apply standard treatment for electrical shock and, if necessary, consult with a physician.
- g. The charger is not for outdoor use. Do not expose the charger to rain or snow.
- h. Do not operate the charger if it has received a sharp blow, been dropped, or otherwise damaged.
- i. Do not disassemble the charger. Have the charger examined by a NATIONAL RAILWAY SUPPLY, INC. service agent. If the charger is assembled incorrectly, damage to the charger and the batteries or an electrical shock may result.

### 2. DESCRIPTION

The NATIONAL RAILWAY SUPPLY, INC. charger and battery pack, model ELC-120/6, included is a convection-cooled, solid state, Silicon Controlled Rectifier (SCR) regulated charger that provides either a constant current or constant voltage output. The charger can be set to charge batteries within a voltage range of 100.0 to 150.0 volts for gel-cell, liquid lead-acid, and starved electrolytic batteries.

### 3. THEORY OF OPERATION

When the charger is connected to the desired AC voltage source (115 or 230), the transformer creates auxiliary voltages for the electronic control module. The electronic control module controls and monitors the charger so it will perform properly. The transformer also supplies the power output used for charging the batteries and provides electrical isolation between the charger's output and the AC source.

The charger's output current flows through a shunt and is sensed by the electronic control module along with the charger's output voltage. These values are converted into drive pulses for the SCRs by the control module. This pulsating charge current (a pulse occurs each time an SCR is on) is then filtered by a large capacitor and the batteries to provide a smooth output.

The charger has an "IE" profile which is: (a) High rate constant current, and (b) Constant voltage. When the charger is first started, the SCRs will conduct for a certain portion of the sinusoidal anode voltage to provide the required charging current at the low level of battery voltage. In this start region, a constant current is applied to the battery. The SCR conduction will then increase as the battery voltage increases in order to provide a higher output voltage while maintaining a constant charging current.

When the battery voltage reaches the float voltage, the SCRs will start to decrease their output. This causes the charger to automatically change from a constant current charge region to a constant voltage charge region. As the batteries become fully charged, the output current decreases. A continuous constant float voltage will be supplied to the batteries to maintain their charge.

Another feature of the charger is temperature compensation, which keeps the batteries from getting under- or over-charged. The red LED on the front of the charger will be off when the temperature probe is functioning. If the LED is on, the on board temperature probe is not working properly.

Temperature compensation uses a temperature reference of 77°F (25°C), a voltage reference of 2.23 volts (the voltage of a standard sealed battery at 77°F), and a compensation value of 3.0 mV per °F). The equivalent equation for the compensated voltage is:

$$V_{\text{comp}} = V - k(t - 77^{\circ}\text{F})$$

Where V is the voltage of the battery at 77°F, t is the temperature in °F, and  $k = V (.003 / 2.23)$ .

The control module has a temperature compensation range between 32°F and 95°F ( 0°C and 35°C) that does not allow charger voltage to increase or decrease beyond the calculated values.

#### Example 1:

If a 133.8 volt battery is charging and the temperature increases to 95°F, then the output voltage decreases to 130.6 volts.

$$133.8 - .18(95^{\circ}\text{F} - 77^{\circ}\text{F}) = 130.6$$

#### Example 2:

If a 145.0 volt battery is charging and the temperature increases to 95°F, then the output voltage decreases to 141.5 volts.

$$145.0 - .195(95^{\circ}\text{F} - 77^{\circ}\text{F}) = 141.5$$

#### Example 3:

If 133.8 volt batteries are charging and the temperature decreases to 32°F, the output voltage increases to 141.9 volts.

$$133.8 - .18(32^{\circ}\text{F} - 77^{\circ}\text{F}) = 141.9$$

### 4. RECEIVING AND INSTALLING THE CHARGER

Proper installation of the charger is important in order to achieve good charger performance and to prevent damage to the charger and batteries. When a charger is received, a check for possible in-transit damage should be made. If any damage is found, it should be reported as a claim to the carrier.

To permit free airflow for convention cooling, allow three inches (3") minimum between the charger and other equipment.

The charger module can be removed from case for lighter weight and ease of handling.

To remove charger module from the case:

- 1). Remove covers screws and open cover door.
- 2). Loosen the four ¼ inch nuts on the back of the charger module, do not remove the nuts.
- 3). Slide charger module along mounting screws until large opening aligns with ¼ inch nuts.
- 4). Lift module from case.

 **WARNING: THE CHARGER MUST BE SET FOR THE PROPER BATTERY VOLTAGE BEFORE STARTING THE INITIAL CHARGE.**

### 5. AC ELECTRICAL SUPPLY

The charger must be connected to a single-phase, 50/60/100 Hertz AC power source, which can be either 115 or 230 VAC depending on charger input voltage selection switch. Use 12 AWG or larger wire

for the AC power input. Quarter-inch (1/4") ring terminals are required for proper connection to the AC input binding posts located behind the front door of the charger. Connect the AC power terminals on the two posts to the right, as marked on the panel. Connect the AC ground to the terminal lug provided.

**⚠️ WARNING: FAILURE TO PROPERLY CONNECT THE AC INPUT COULD CAUSE SERIOUS DAMAGE TO THE CHARGER. BE SURE TO SET THE VOLTAGE SELECTION SWITCH ON THE FRONT OF THE CHARGER MODULE TO THE PROPER POSITION.**

**⚠️ WARNING: DO NOT OPERATE THE CHARGER WITHOUT PROPER GROUNDING. IMPROPER GROUNDING CAN RESULT IN THE RISK OF AN ELECTRIC SHOCK.**

## 6. DC OUTPUT

The DC output wires, 8 AWG or larger, are connected on the two left-most binding posts as marked on the panel (positive on the left and negative on the right). The DC cables should have quarter-inch (1/4") ring terminals for connecting them to the binding posts. Check to make sure the polarity of the DC output cables is the same as the load.

### Battery Installation

- 1). Battery shelves are located on left side of case. Bottom two shelves hold three or four batteries each and the top shelf holds one, two, or three batteries depending on the battery type.
- 2). Included in the battery interconnect kit are the wires and print # 33364 and #34012 which illustrates proper battery interconnection.
- 3). Starting on the bottom left shelf and using the diagram as a guide, connect the batteries. The rear battery connection must be made before the battery is installed in the case. Take care not to short out the battery.
- 4). After all battery connections are made check battery connector for proper voltage and polarity.
- 5). Plug battery connector into charger module connector and close door.

The charger will not operate if battery polarity is reversed. If the DC battery polarity is reversed, a fuse will protect the charger from internal damage. Correct the reversed wires and replace the fuse.

**⚠️ WARNING: DO NOT TOUCH THE CHARGER'S TERMINALS OR AN ELECTRICAL SHOCK COULD OCCUR. A VOLTAGE IS PRESENT ON THE DC TERMINALS EVEN AFTER THE AC IS DISCONNECTED BECAUSE OF THE**

## ENERGY STORED IN THE BATTERIES AND CAPACITOR.

## 7. TEMPERATURE PROBE

The on board temperature probe is a way of extending battery life by using temperature compensation.

## 8. OPERATION

The battery charger is adjustable with the three rotary switches on the front of the charger. The switches (settable between 100.0 and 150.0) determine the float voltage for the batteries. **SET THE FLOAT VOLTAGE TO THE BATTERY MANUFACTURER'S SPECIFIED VOLTAGE FOR 77°F.** The charger will then electronically charge the batteries to the voltage specified on the switches. To set the switches, use a small screwdriver and turn the switch so that the arrowhead on the slot is pointing to the desired number. Set the switches in the following manner: If the desired battery voltage is 122.6 volts, set the top switch to 2, the middle switch to 2, and the bottom switch to 6 (see the figure 8.1). This will provide you with the proper charging voltage. The hundreds digit is always a one (1) and cannot be changed. **BE SURE EACH SWITCH IS SET ON A NUMBER AND NOT BETWEEN NUMBERS.** If a switch is set between numbers, the output current will go to zero and the yellow charging LED will flash.

The charger does not have a power switch. When AC power is applied to the charger, battery charging will start and the yellow LED will be on. To turn the charger off, disconnect the AC power source.

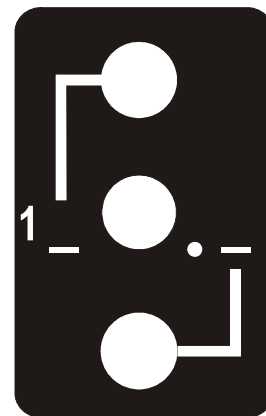

Figure 8.1

## 9. MAINTENANCE

The battery charger requires minimal maintenance. It should be kept clean and all connections are to be periodically tightened. **BE SURE THE CHASSIS IS**

**SECURELY GROUNDED.** If any problem cannot be resolved, consult the nearest NRS service agent.

### 10. SERVICING

If the battery charger operates improperly, follow the steps below.

- a. Disconnect AC power
- b. Check the DC voltage switches to verify their settings against the specifications of the batteries.
- c. Open the door on the front of the charger and make sure all of the binding posts nuts are tight.

**⚠ WARNING: DO NOT TOUCH THE CHARGER'S TERMINALS OR AN ELECTRICAL SHOCK COULD OCCUR. A VOLTAGE IS PRESENT ON THE DC TERMINALS EVEN AFTER THE AC IS DISCONNECTED BECAUSE OF THE ENERGY STORED IN THE BATTERIES AND CAPACITOR.**

- d. Check the AC voltage selection switch for the proper setting.
- e. Check the AC and DC fuses to make sure they have not blown.
- f. Check the polarity between DC output and the battery and make sure the battery connections are tight.
- g. If the steps above do not solve the problem, contact your local NRS service agent.

### 11. CHARGER SPECIFICATIONS

AC INPUT VOLTAGE:

115 Vac (108-128) or 230 Vac (216-256)

AC INPUT CURRENT:

13.5 amps for 115 Vac (full power, 60Hz)

7.0 amps for 230 Vac (full power, 60Hz)

AC INPUT FREQUENCY:

50/60/100 Hertz (single phase)

AC LINE REGULATION:

For a constant output current at 2.27 volts/cell  
10% for 60 cells

AC FUSES:

10 Amp time delay

DC FUSE

20 Amp time delay

DC OUTPUT:

Voltage range 100.0 – 150.0 ± 1 volt

Current Maximum 6.0 ± .3 amp

TEMPERATURE COMPENSATION:

3mV per °F per cell

WEIGHT, NET:

230 lbs. with 10 batteries

90 lbs. without batteries installed

### 12. BATTERY SPECIFICATIONS

12 Volt 6 cell

17.2 or 15.0 AH Sealed lead acid

-----

### 13. PARTS LIST

The following is a list of parts found in the NRS Model ELC 120/6. When replacing a part, USE ONLY ORIGINAL FACTORY REPLACEMENT PARTS of the correct size and rating.

<b>PART NO.</b>	<b>QTY.</b>	<b>DESCRIPTION</b>
24685S	1	TRANSFORMER ASSEMBLY (ELC 120/6)
24620S	1	CONTROL BOARD
33262S	1	CONTROL CABLE
24700S	1	CONTROL MODULE ASSEMBLY
33143S	1	BASE ASSEMBLY
33163S	1	COVER ASSEMBLY
05322S	3	FUSEHOLDER ASSEMBLY
15028S	2	FUSE, 10 AMP TIME DELAY
10749S	1	FUSE, 20 AMP TIME DELAY
31457S	1	AC SWITCH ASSEMBLY
14197S	6	BUSHING, 1"
26769S	2	SCR, 22 AMP, 600 VOLT
33288S	1	OUTPUT CAPACITOR, C, 1,500 UF, 200V
14786S	1	DIODE ASSEMBLY, D
33289S	1	CAP ASSEMBLY, W/ DIODE ASSEMBLY
32884S	1	VARISTOR, 130 V, VR2
31309S	1	VARISTOR ASSEMBLY, 320 V, VR1
33153S	1	SIDE PANEL, RIGHT
33156S	1	SIDE PANEL, LEFT
25308-CSP	9 or 10	BATTERY, 12 V, 17.2 AH NP 18-12 (CONTACT NATIONAL RAILWAY SUPPLY)
33369S	1	BATTERY INTERCONNECT WIRE KIT FOR NP 18-12
34007S	1	BATTERY INTERCONNECT WIRE KIT FOR SBS J16X BATTERIES, OPTION -19 & -19-CSX
34019-CSP	9 or 10	BATTERY, 12 V, 15.0 AH SBS J16 (CONTACT NATIONAL RAILWAY SUPPLY)
34427S	1	BATTERY INTERCONNECT WIRE KIT FOR SBS J16 BATTERIES, OPTION -20 ONLY

# 14. WIRING DIAGRAM

ELC-120/6

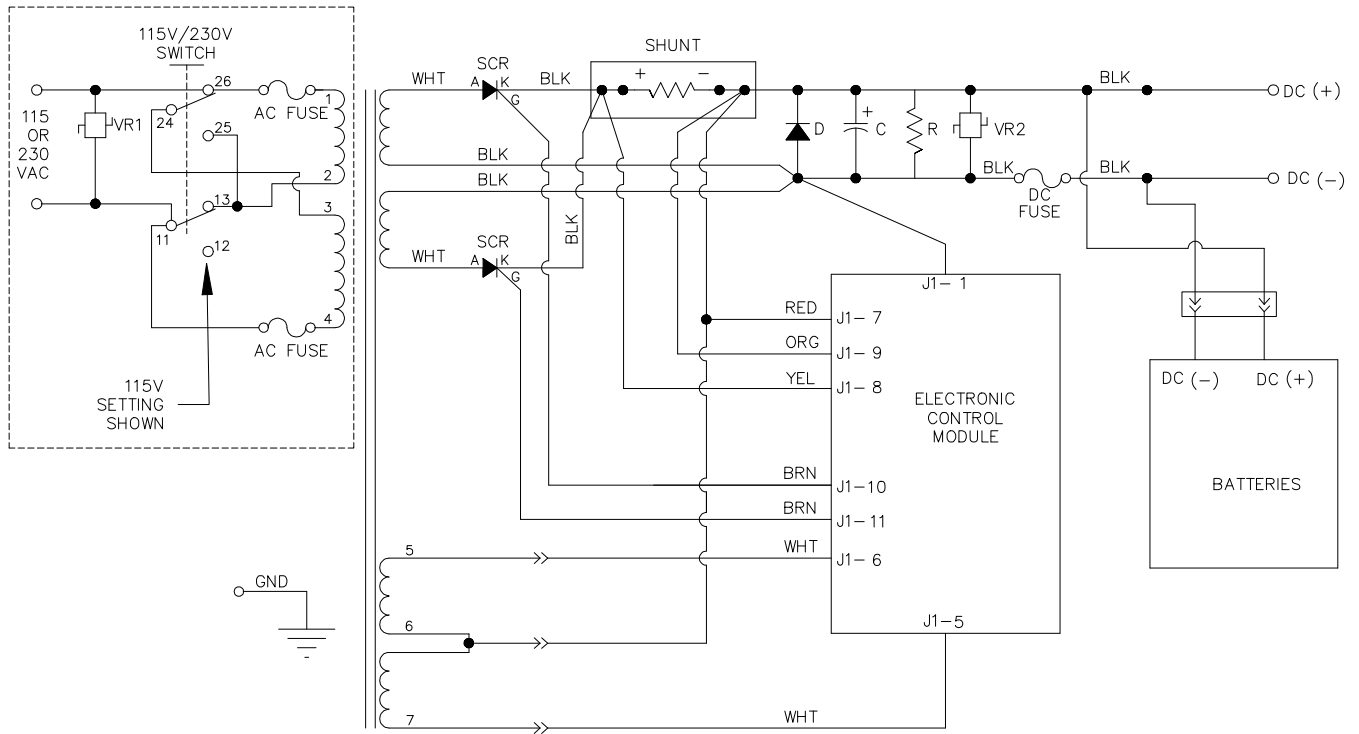

J1-1	BLACK	- BATTERY
J1-5	WHITE	AC XFRMR #8
J1-6	WHITE	AC XFRMR #5
J1-7	RED	+ BATTERY
J1-8	YELLOW	SHUNT +
J1-9	ORANGE	SHUNT -
J1-10	BROWN	SCR
J1-11	BROWN	SCR

C	OUTPUT CAPACITOR
R	RESISTOR
D	DIODE ASSEMBLY
VR1	VARISTOR
VR2	VARISTOR

L2120B45