

**NATIONAL
RAILWAY
SUPPLY**

Installing, Operating and
Service Instructions for the
12/60 Solid State Charger

MODEL ELC-12/60-CVM-D BATTERY CHARGER

PLEASE SAVE THESE IMPORTANT SAFETY AND OPERATING INSTRUCTIONS

For correct operation of the equipment, it is important to read and be familiar
with this entire manual before installing and operating the charger.
DO NOT DISCARD THIS MANUAL AFTER READING.



**LOOK FOR THIS SYMBOL TO POINT OUT SAFETY PRECAUTIONS. IT MEANS:
BECOME ALERT—YOUR SAFETY IS INVOLVED. IF YOU DO NOT FOLLOW THESE
SAFETY INSTRUCTIONS, INJURY OR PROPERTY DAMAGE CAN OCCUR.**

1. IMPORTANT SAFETY INSTRUCTIONS

- a. Before using the battery charger, read all the instructions and caution markings on the battery charger, the battery, and all of the products using the battery.
- b. Do not touch the uninsulated parts of the AC input or the DC wires, the charger's binding posts, or the battery terminals, as there is a possibility of electrical shock.
- c. Batteries produce hydrogen gas while operating, which can explode if ignited. Never smoke, use an open flame, or create sparks in the vicinity of the battery. Ventilate the area well when the battery is charging in an enclosed area.
- d. Batteries contain caustic material which may cause burns. Do not get in eyes, on skin, or clothing. If the gelled or liquid content of the batteries contacts the skin or clothing, wash the area thoroughly with water. In the case of contact with the eyes, flush immediately with clean water for 15 minutes and obtain medical attention.
- e. Only qualified personnel should program or service this equipment.
- f. De-energize all AC and DC power connections before servicing this unit. If injury does occur, apply standard treatment for electrical shock and, if necessary, consult with a physician.
- g. The charger is not for outdoor use. Do not expose the charger to rain or snow.
- h. Do not operate the charger if it has received a sharp blow, been dropped, or otherwise damaged.
- i. Do not disassemble the charger. Have the charger examined by a NATIONAL RAILWAY SUPPLY service agent. If the charger is assembled incorrectly, damage to the charger and the batteries or an electrical shock may result.

2. DESCRIPTION

The NATIONAL RAILWAY SUPPLY charger, model ELC-12/60-CVM-D, is a convection-cooled, solid state, SCR regulated charger that provides either a constant current or constant voltage output. The charger can be set to charge batteries within a voltage range of 10.00 to 17.00 volts for gel-cell, liquid lead-acid, nickel cadmium, nickel iron, and starved electrolytic batteries.

3. THEORY OF OPERATION

When the charger is connected to the desired AC voltage source (115 or 230), the transformer creates auxiliary voltages for the electronic control module. The electronic control module controls and monitors the charger so it will perform properly. The transformer also supplies the power output used for charging the batteries and provides electrical isolation between the charger's output and the AC source.

The charger's output current flows through a shunt and is sensed by the electronic control module along with the charger's output voltage. These values are converted into drive pulses for the SCRs by the control module. This pulsating charge current (a pulse occurs each time an SCR is on) is then filtered by a large capacitor and the batteries to provide a smooth output.

The charger has an "IE" profile which is: (a) High rate constant current, and (b) Constant voltage. When the charger is first started, the SCRs will conduct for a certain portion of the sinusoidal anode voltage to provide the required charging current at the low level of battery voltage. In this start region, a constant current is applied to the battery. The SCR conduction will then increase as the battery voltage increases in order to provide a higher output voltage while maintaining a constant charging current.

When the battery voltage reaches the float voltage, the SCRs will start to decrease their output. This causes the charger to automatically change from a constant current charge region to a constant voltage charge region. As the batteries become fully charged, the output current decreases. A continuous constant float voltage will be supplied to the batteries to maintain their charge.

Another feature of the charger is temperature compensation, which keeps the batteries from getting under- or over-charged. **TEMPERATURE COMPENSATION ONLY OCCURS WHEN USING A TEMPERATURE PROBE.** The red LED on the front of the charger will be off when using a functional temperature probe. If the LED is on, either a temperature probe is not being used, or the temperature probe is working improperly.

Temperature compensation uses a temperature reference of 77°F (25°C), a voltage reference of 2.23 volts (the voltage of a standard gel-cell battery at 77°F), and a compensation value of 3.0 mV per °F). The equivalent equation for the compensated voltage is:

$$V_{\text{comp}} = V - k(t - 77^{\circ}\text{F})$$

Where V is the voltage of the battery at 77°F, t is the temperature in °F, and $k = V (.003 / 2.23)$.

The control module has a temperature compensation range between 32°F and 95°F (0°C and 35°C) that does not allow charger voltage to increase or decrease beyond the calculated values.

Example 1:

If a 13.38 volt battery is charging and the temperature increases to 95°F, then the output voltage decreases to 13.06 volts.

$$13.38 - .018 (95^{\circ}\text{F} - 77^{\circ}\text{F}) = 13.06$$

Example 2:

If a 14.50 volt battery is charging and the temperature increases to 95°F, then the output voltage decreases to 14.15 volts.

$$14.50 - .0195 (95^{\circ}\text{F} - 77^{\circ}\text{F}) = 14.15$$

Example 3:

If 15.61 volt batteries are charging and the temperature decreases to 32°F, the output voltage increases to 16.56 volts.

$$15.61 - .021 (32^{\circ}\text{F} - 77^{\circ}\text{F}) = 16.56$$

4. RECEIVING AND INSTALLING THE CHARGER

Proper installation of the charger is important in order to achieve good charger performance and to prevent damage to the charger and batteries. When a charger is received, a check for possible in-transit damage should be made. If any damage is found, it should be reported as a claim to the carrier. To permit free air flow for convection cooling, allow three inches (3") minimum between the charger sides and other equipment and four inches (4") minimum on top of the charger.

 WARNING: NEVER PLACE ANYTHING ON TOP OF THE CHARGER WHILE OPERATING. DAMAGE TO THE CHARGER OR BATTERIES COULD OCCUR.

 WARNING: THE CHARGER MUST BE SET UP FOR THE PROPER USER SPECIFICATIONS BEFORE STARTING THE INITIAL CHARGE.

5. AC ELECTRICAL SUPPLY

The charger must be connected to a single-phase, 50/60/100 Hertz AC power source, which can be either 115 or 230 VAC depending on the charger switch position. Use an appropriate size wire for the AC power input. Quarter-inch (1/4") ring terminals are required for proper connection to the AC input and ground binding posts (A.A.R.) located on the front of the charger. Open the small door cover on the front of the charger by pulling out on

the push tabs. Connect the AC power terminals on the two posts on the right, as marked on the panel behind the posts. Connect the AC ground to the terminal lug provided.

⚠ WARNING: FAILURE TO PROPERLY CONNECT THE AC VOLTAGE CONDUCTORS COULD CAUSE SERIOUS DAMAGE TO THE CHARGER. **BE SURE TO SET THE VOLTAGE SELECTION SWITCH ON THE FRONT OF THE CHARGER TO THE PROPER POSITION.**

⚠ WARNING: DO NOT OPERATE THE CHARGER WITHOUT PROPER GROUNDING. IMPROPER GROUNDING CAN RESULT IN THE RISK OF AN ELECTRIC SHOCK.

6. DC OUTPUT

The DC output wires, 4 Awg or larger, are connected on the two left-most binding posts as marked on the panel behind the posts (positive on the left and negative on the right). The DC cables should have quarter-inch (1/4") ring terminals for connecting them to the binding posts. Check to make sure the polarity of the DC output wires are the same as those connected to the battery. The charger will not operate in a reversed polarity condition. **WHEN CONNECTING THE DC WIRES TO THE CHARGER WITH THE AC POWER DISCONNECTED, A SPARK MAY OCCUR.** This is caused by the output capacitors being charged by the batteries. If the DC polarity is reversed, a circuit breaker will protect the charger from internal damage. Correct the reversed wires and reset the circuit breaker. Close the door cover on the front of the charger after tightening all of the binding post nuts.

⚠ WARNING: DO NOT TOUCH THE CHARGER'S TERMINALS OR AN ELECTRICAL SHOCK COULD OCCUR. A VOLTAGE IS PRESENT ON THE DC TERMINALS EVEN AFTER THE AC IS DISCONNECTED BECAUSE OF THE ENERGY STORED IN THE CAPACITOR.

7. TEMPERATURE PROBE

The external temperature probe is an optional way of extending battery life by using temperature compensation. One end of the temperature probe cable has a three-pin plug, which plugs into a receptacle labeled TEMP PROBE on the front of the charger. The other end of the cable has the temperature sensor sealed either in a terminal or small metal box.

⚠ WARNING: IT IS IMPORTANT TO MOUNT THE TEMPERATURE PROBE ON THE BATTERIES FOR PROPER TEMPERATURE COMPENSATION. IF THIS CANNOT BE DONE, LOCATE THE PROBE AS LOW AS POSSIBLE IN THE BUNGALOW OR CABINET.

Terminal-Type Probe

The terminal-type probe should be attached to the negative (-) battery post near the center of the battery pack. If the threaded stud is long enough above the battery jumper nut, attach the probe with another nut. Torque this nut to proper specifications. If the stud is too short, the nut holding the jumper wire will need to be removed. Open or remove the load and charging circuits to the batteries. Remove the nut holding the jumper and add the probe, then torque the nut to the proper specifications. Then close or connect the load and charging circuits back to the batteries.

Securely fasten the temperature probe cable to protect the probe from being torn from the battery. Secure the probe's cable to a fixed object to ensure the probe will not be pulled loose. Use a cable tie mount on the battery or on the adjacent battery, if necessary.

8. OPERATION

The battery charger is adjustable with the three rotary switches on the front of the charger. The switches (settable between 10.00 and 17.00) determine the float voltage for the batteries. **SET THE FLOAT VOLTAGE TO THE BATTERY MANUFACTURER'S SPECIFIED VOLTAGE FOR 77°F.** The charger will then electronically charge the batteries to the voltage specified on the switches. To set the switches, use a small screwdriver and turn the switch so that the arrowhead on the slot is pointing to the desired number. Set the switches in the following manner: If the desired battery voltage is 13.38 volts, set the top switch to 3, the middle switch to 3, and the bottom switch to 8 (see the figure 8.1). This will provide you with the proper charging voltage. The tens digit is always a one (1) and cannot be changed. **BE SURE EACH SWITCH IS SET ON A NUMBER AND NOT BETWEEN NUMBERS.** If a switch is set between numbers, the output current will go to zero and the yellow charging LED will flash.

The charger does not have a power switch. When the AC power is applied to the charger, the DC output will start and the yellow LED will be on. To turn off the charger, disconnect the AC power source.

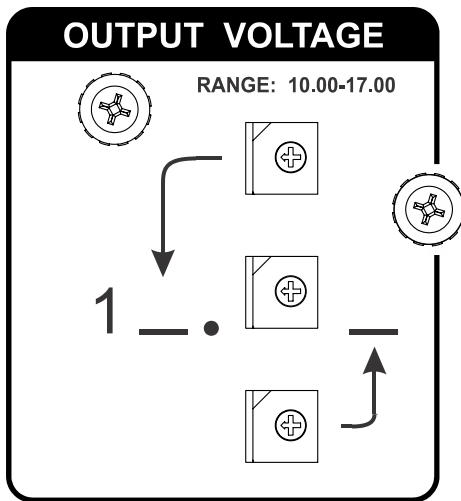

Figure 8.1

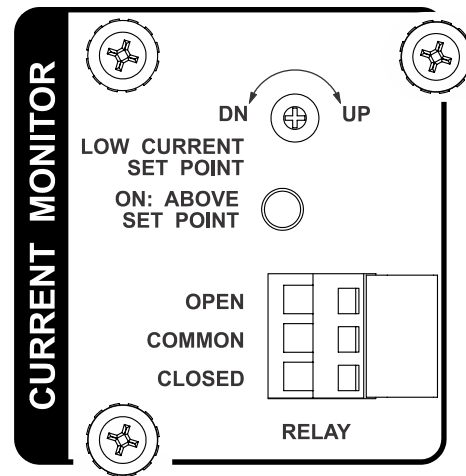

Figure 9.1

9. CURRENT MONITOR/ALARM

The ELC-12/60-CVM-D battery charger includes an integrated current monitor/alarm that monitors the output current of the charger. If the charger output falls below the low current set point, a green LED indicator is turned off and a Form C, dry contact alarm relay is actuated. The low current set point adjustment, LED, and relay terminals are accessible on the front of the charger (see Figure 9.1).

Relay Terminal Remote Wiring

The OPEN, COMMON, and CLOSED relay contacts have push-in type terminals for remote wiring. The relay contacts are rated for 1A at 30 Vdc or 0.5A at 120 Vac. A small screwdriver (3/32 inch maximum blade width) is required to insert or remove a wire from a relay terminal.

⚠ WARNING: BE CAREFUL! IF AN UNINSULATED METAL TOOL CONTACTS BOTH THE GROUNDED CHARGER CASE AND A RELAY TERMINAL PUSH-IN TAB, THIS WILL CAUSE A POTENTIALLY DAMAGING AND/OR DANGEROUS ELECTRICAL SHORT.

Current Monitor/Alarm Operation

Table 9.1 outlines the operation of the LED and relay based on the status of the current monitor. All relay contact states are with reference to the terminal strip COMMON.

Current Monitor Status	LED	CLOSED Relay Contact	OPEN Relay Contact
Charger output exceeds the low current set point	On	Closed	Open
Charger output falls below the low current set point (and AC power is present at the charger)	Off (within 30 seconds)	Open (within 30 seconds)	Closed (within 30 seconds)
AC power is removed from the charger	Off (immediately)	Open (immediately)	Closed (immediately)

Table 9.1

Low Current Set Point

The low current set point adjustment should be set to a level that is below the charger output when sourcing the minimum DC load of the system and floating the fully charged battery set. The low current set point adjustment is factory-set to approximately 400 mA (fully clockwise), which should work for most applications. If the minimum DC load of the system combined with the battery float current is above approximately 500 mA, leaving the low current set point adjustment at the factory setting of 400 mA is recommended. If an adjustment is required, it can be adjusted between approximately 400 mA and 70 mA.

Adjustment Procedure

A small screwdriver (3/32 inch maximum blade width) is required to change the low current set point adjustment.

With AC power applied to the charger input and the charger DC output connected to the load and fully charged battery set, monitor the charger output current until it stops decreasing and levels off at the minimum system current. Ensure that the low current set point adjustment is turned fully clockwise, which will set the low current set point at approximately 400 mA. If the LED is on and the CLOSED relay contact is closed when the low current set point adjustment is turned fully clockwise, leave it in that position. If the LED is off and the CLOSED relay contact is open when the low current set point adjustment is turned fully clockwise, turn it slowly counterclockwise until the LED turns on and the CLOSED relay contact closes. Turn the low current set point adjustment approximately 1/8 of a turn counterclockwise from this switching point. Remove AC power from the charger to verify that the current monitor/alarm is functioning. The LED should turn off and the CLOSED relay contact should open.

Current Monitor/Alarm Specifications

RELAY CONTACT RATINGS:

1A at 30 Vdc

0.5A at 120 Vac

TERMINAL CONNECTIONS:

20 – 16 AWG wire, strip length of .312 - .359 inches (8 – 9 mm)

10. VOLTAGE MONITOR/ALARM

The ELC-12/60-CVM-D battery charger includes an integrated voltage monitor/alarm that monitors the DC voltage. Unless the optional VOLTAGE MONITOR BATTERY SENSE input available on the front of the charger is remotely wired to the terminals of the battery, the DC voltage is monitored internally at the charger output. If the DC voltage rises above the HIGH VOLTAGE (HV) SET POINT setting, the green BELOW HV SET POINT LED indicator is turned off and the Form C, dry contact alarm relay is actuated. If the DC voltage falls below the LOW VOLTAGE (LV) SET POINT setting, the green ABOVE LV SET POINT LED indicator is turned off and the Form C, dry contact alarm relay is actuated. The voltage set point switches, LEDs, relay terminals, and optional battery sense input are accessible on the front of the charger (see Figure 10.1).

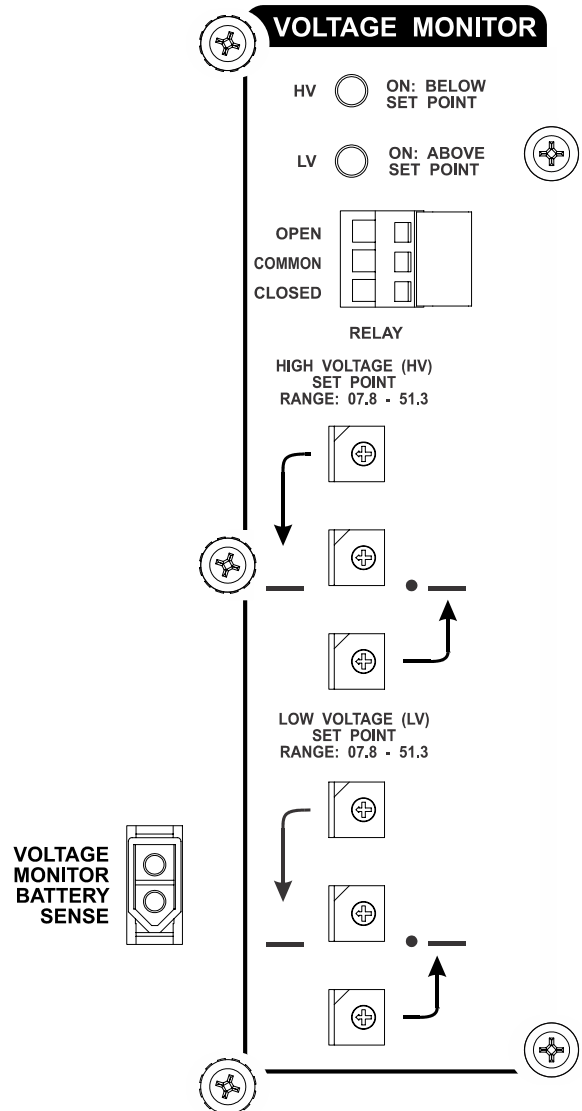

Figure 10.1

Relay Terminal Remote Wiring

The OPEN, COMMON, and CLOSED relay contacts have push-in type terminals for remote wiring. The relay contacts are rated for 1A at 30 Vdc or 0.5A at 120 Vac. A small screwdriver (3/32 inch maximum blade width) is required to insert or remove a wire from a relay terminal.

⚠ WARNING: BE CAREFUL! IF AN UNINSULATED METAL TOOL CONTACTS BOTH THE GROUNDED CHARGER CASE AND A RELAY TERMINAL PUSH-IN TAB, THIS WILL CAUSE A POTENTIALLY DAMAGING AND/OR DANGEROUS ELECTRICAL SHORT.

Table 10.1 outlines the operation of the LEDs and alarm relay based on the status of the voltage monitor. All relay contact states are with reference to the terminal strip COMMON. The voltage monitor/alarm is DC powered, so, if the charger loses AC power, the voltage monitor/alarm will continue to function on battery power until the DC voltage falls below approximately 7.1 volts, where it will continue to be in an alarm state until AC power is returned to the charger and the charger is able to raise the DC voltage above the LOW VOLTAGE (LV) SET POINT setting.

Voltage Set Point Adjustments

The HIGH VOLTAGE (HV) SET POINT setting is adjustable with three (3) rotary switches and the LOW VOLTAGE (LV) SET POINT setting is adjustable with three (3) rotary switches, all of which are available on the front of the charger (see Figure 10.1). For both settings, the top switch sets the tens of volts, the middle switch sets the volts, and the

bottom switch sets the tenths of volts. Both set points are settable between 07.8 and 51.3 volts. To set the switches, use a small screwdriver to turn the switch so that the arrowhead on the slot is pointing to the desired number. **BE SURE EACH SWITCH IS SET ON A NUMBER AND NOT BETWEEN NUMBERS.** If a switch is set between numbers, the corresponding LED will flash, and the voltage monitor/alarm will not function as intended.

Voltage Monitor Battery Sense Input (Optional)

The voltage monitor/alarm includes an optional VOLTAGE MONITOR BATTERY SENSE input available on the front of the charger (see Figure 10.1). If the VOLTAGE MONITOR BATTERY SENSE input is left disconnected, the DC voltage is monitored internally at the charger output. The VOLTAGE MONITOR BATTERY SENSE input can be remotely wired to the terminals of the battery to monitor the voltage at this point. The voltage monitor/alarm detects when the VOLTAGE MONITOR BATTERY SENSE input is connected to the battery terminals and automatically monitors this DC voltage instead of the voltage at the charger output. Please refer to the wiring diagram in Section 15 for the VOLTAGE MONITOR BATTERY SENSE input connector detail.

Voltage Monitor/Alarm Specifications

RELAY CONTACT RATINGS:

1A at 30 Vdc
0.5A at 120 Vac

TERMINAL CONNECTIONS:

20 – 16 AWG wire, stripe length of .312 - .359 inches (8 – 9 mm)

Voltage Monitor Status	BELOW HV SET POINT LED	ABOVE LV SET POINT LED	CLOSED Relay Contact	OPEN Relay Contact
DC voltage is below the HIGH VOLTAGE (HV) SET POINT setting and above the LOW VOLTAGE (LV) SET POINT setting (normal operation state)	On	On	Closed	Open
DC voltage is above the HIGH VOLTAGE (HV) SET POINT setting and above the LOW VOLTAGE (LV) SET POINT T setting (high DC voltage alarm state)	Off	On	Open	Closed
DC voltage is below the HIGH VOLTAGE (HV) SET POINT setting and below the LOW VOLTAGE (LV) SET POINT setting (low DC voltage alarm state)	On	Off	Open	Closed

Table 10.1

11. MAINTENANCE

The battery charger requires minimal maintenance. It should be kept clean and all connections are to be periodically tightened. **BE SURE THE CHASSIS IS SECURELY GROUNDED.** If any problem cannot be resolved, consult the nearest NRS service agent at 1-800-357-3572.

12. SERVICING

If the battery charger operates improperly, follow the steps below.

- a. Begin by checking the voltage switches to verify their settings against the specifications of the batteries.
- b. Check the AC voltage selection switch for the proper setting.
- c. Check the fuses to make sure they have not blown.
- d. Check the circuit breaker to see if it has opened and reset it, if necessary.
- e. Check the polarity between DC output and the battery and make sure their connections are tight.
- f. Remove the small cover on the front of the charger and make sure all of the binding posts nuts are tight.
- g. If the steps above do not solve the problem, contact your local NRS service agent at 1-800-357-3572.

13. CHARGER SPECIFICATIONS

AC INPUT VOLTAGE:

115 Vac (108-128) or 230 Vac (216-256)

AC INPUT CURRENT:

17 amps for 115 Vac (full power)

9 amps for 230 Vac (full power)

AC INPUT FREQUENCY:

50/60/100 Hertz (single phase)

AC LINE REGULATION:

For a constant output current at 2.23 volts/cell

17% for 6 cells

AC FUSES:

15 Amp slow blow

POWER FACTOR:

Percentage at 60.0 amps DC current

61% at 13.38 volts

79.5% at 17.0 volts

DC OUTPUT:

Voltage range 10.00 – 17.00 \pm 0.1 volts

Current maximum 60.0 \pm 1.5 amps

DC OUTPUT RIPPLE (at battery terminals):

0.6 V p-p at 60.0 amps, 12.0 volts

0.1 V p-p at 2.0 amps, 13.38 volts

TEMPERATURE COMPENSATION:

3mV per °F per cell

WEIGHT, NET: 75 lbs

14. PARTS LIST

The following is a list of parts found in the NRS model ELC-12/60-CVM-D. When replacing a part, USE ONLY ORIGINAL FACTORY REPLACEMENT PARTS of the correct size and rating.

PART NO.	QTY.	DESCRIPTION
39048S	1	CASE ASSEMBLY MODEL 27960
31509S	1	CONTROL MODULE (W/ ELECTRONIC BOARD #22655)
05322S	1	FUSEHOLDER ASSEMBLY
16499S	1	FUSE, 15 AMP
32201S	1	CIRCUIT BREAKER 100 AMP
31928S	1	BRACKET CIRCUIT BREAKER
38901S	1	AC SWITCH ASSEMBLY (ELC 12/60-D ONLY)
14947S	1	SHUNT ASSEMBLY
32644S	1	AMMETER, 75 AMP
29741S	1	TEMPERATURE TRANSDUCER, 10' (W/ TERMINAL)
29742S	1	TEMPERATURE TRANSDUCER, 30' (W/ TERMINAL)
11232S	4	HEATSINK
23168S	1	THYRISTOR ASSEMBLY, 80 AMP 600VDC SCR 17"
23167S	1	THYRISTOR ASSEMBLY 80 AMP 600VDC SCR 5"
32206S	1	CAP ASSEMBLY, W/ DIODE ASSEMBLY (2 CAPACITORS)
14759S	1	VARISTOR ASSEMBLY, VR2, 130V
31309S	1	VARISTOR ASSEMBLY, VR1, 320V
14197S	4	BUSHING, 1"
31301S	1	LATCH DOOR BASE
31302S	1	LATCH DOOR STUD
38808S	1	VOLTAGE MONITOR MODULE (W/ ELECTRONIC BOARD #27775)
38856S	1	CABLE CONTROL VOLTAGE MONITOR
15369S	1	REMOTE VOLTAGE SENSE CABLE, 10'
24584S	1	REMOTE VOLTAGE SENSE CABLE, 30'
38804S	1	CURRENT MONITOR MODULE (W/ ELECTRONIC BOARD #27545-02)
38878S	1	CONTROL CABLE, CURRENT MONITOR

15. WIRING DIAGRAM

